



**SLP80F-12 PORTABLE FOLDING 12V 80W SOLAR
POWER BATTERY CHARGER**
(WITH BUILT-IN LED INDICATION AUTOMATIC CONTROLLER)

**INSTRUCTION MANUAL &
SPECIFICATIONS**

Available From:

SolarPanelStore.com



**COMPACT FOR STORAGE
AND TRANSPORTATION**



SLP80F-12 FEATURES:

Convenient Carry Bag

Constructed of high denier (600d), this water resistant polyester bag is fully padded with reinforced corners & protectors to ensure safe transportation & staging.



Easy Carry Handle & Safety Fasteners

Panels are fitted with a heavy duty handle allowing for easy handling & removal from the protective carry bag. Two clip-type safety fasteners lock the panel shut during transportation



Built in Smart Solar Controller with LED Indication

Mounted behind the panels, this controller ensures the safety of the panels & the batteries. This SMART controller with automatically cut out when the batteries are fully charged, during solar panel discharge & in situations where reverse polarity may exist. Controller features a switch allowing use with lead-acid & gel type batteries.



Constant YELLOW LED: Indicates charging.
Constant YELLOW/GREEN LEDs: Indicates fully charged.

Fold Away Support Leg

Unique, ratcheted folding system is easy to open & close, keeping the panels at the desired angle without slipping. The angle can be easily adjusted throughout the day to ensure maximum sun exposure & maximum power output.



Connecting Cables

System comes complete with 5m cable extending from the controller. This cable features a 10A in-line fuse. 3 connection options are included; ...battery clamps, car cigarette lighter plug & car cigarette lighter socket.



SLP80F-12 KIT COMPONENTS:

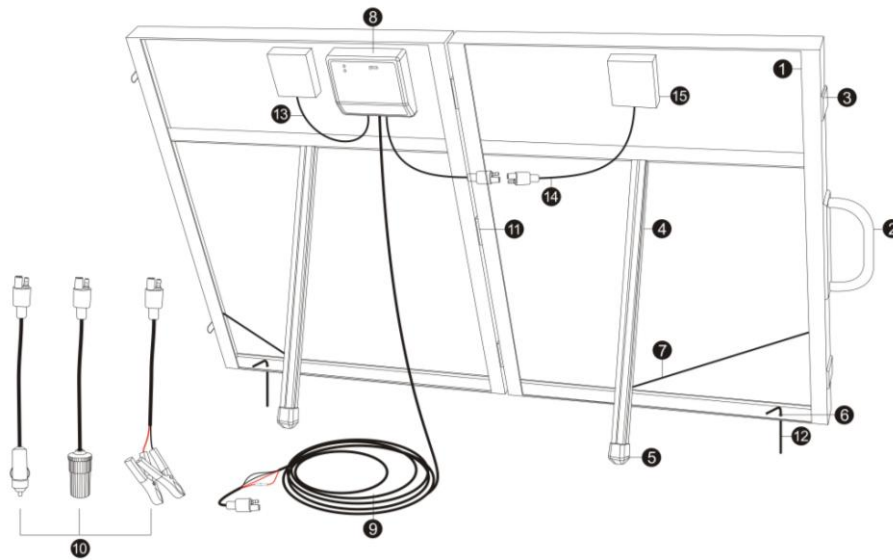

1. 2 x 40w multi-crystalline silicon solar panels with heavy-duty anodized aluminium frame. Panels connected in series (See Item #14) providing 80W output.
2. ABS carry handle.
3. Clip-type steel safety fasteners.
4. Anodized aluminium folding support legs. Ratchet design to eliminate slipping.
5. Anti-slip rubber feet.
6. Pin holes for use with ground secure pins.
7. Steel rope between panels & support legs.
8. SMART solar controller with LED (green/yellow) indicators & battery type (Lead-Acid or Gel) selector switch.
9. 5m/16.4ft cable from controller with male/female connection to attach to items in connection kit (Item #10). Cable features a 10A in-line fuse.
10. Connection kit includes the following 3 options (All connections are 15cm/5.90" in length) :
 - a. Battery Clamps.
 - b. Car Cigarette Lighter Male Connector.
 - c. Car Cigarette Lighter Female Connector.
11. 3 hinges.
12. Steel secure pins.
13. Connection cable between the solar panel & the controller.
14. Connection cable between the solar panel & the controller.
15. Solar panel junction box, one on each panel.
16. 600D water resistant, durable polyester padded bag. (Not Shown)
17. Instruction manual.

SPECIFICATIONS:

SOLAR PANEL:

Type:	2 x Multi-Crystalline silicon solar cell
Rated Power (Pm):	80W (2 x 40W panels in series)
Operating Voltage (Vmp):	17.2V
Operating Current (Imp):	4.65A
Open Circuit Voltage (Voc):	21.6V
Short Circuit Current (Isc):	5.17A
Power Tolerance:	±5%
Operating temperature:	-40°C ~ +85°C
Standard Test Conditions:	Irradiance (E) -1000W/M ² , AM 1.5 Spectrum, Panel Temp. (Tc) =25°C

SOLAR PANEL CONTROLLER:

Model:	SLC-1207
Type:	SMART - Automatic
Rated voltage:	12VDC
Rated current:	7A
Max. Input voltage:	25V
Operating voltage:	8V
<i>(Minimum Charge Start – Controller will not work with a battery lower than 8V)</i>	
Operating temperature:	-20°C ~ +60°C

IN-LINE FUSE:

Type:	Standard Glass Automotive
Rated:	10A

RECOMENDED BATTERIES (Not Included):

12V (60Ah~100Ah) Lead-Acid or GEL type

DIMENSIONS:

Individual 40W Solar Panel:	670mm x 530mm x 40mm 26.4" x 20.86" x 1.57"
With Panels Folded:	670mm x 530mm x 80mm 26.4" x 20.86" x 3.14"
With Panels Open:	670mm x 1065mm x 40mm 26.4" x 41.92" x 1.57"

PACKAGING:

Kits are placed in the padded bags & individually packed in separate cartons consisting of heavy corrugated cardboard.

Carton Size:	700mm x 110mm x 595mm 27.55" x 4.33" x 23.42"
Weight (NW/GW):	15kg/18kg 33lbs/39.60lbs

INSTALLATION & CONNECTION:

STEP 1: LOCATION:

Identify the best location allowing for maximum sun exposure. Location should be well ventilated.

Keep away from obvious hazards such as; ...camp fires, water, high-traffic areas, shadows, etc.

STEP 2: SET-UP (No Tools Required):

Remove the SLP80F-12 kit from the padded bag.

Open the folding solar panels & fold out the support legs.

Adjust the legs to provide the desired angle & direction that allows for maximum sun exposure. Secure panels in position.

Direction & angle can be adjusted throughout the day for maximum power.

STEP 3: CONNECT PANELS:

The panel that has the controller mounted on the back is already connected to the controller.

Connect the other panel to the controller using the provided cables & connections.

STEP 4: CONNECT TO BATTERY

Ensure the controller is set to the correct battery type (Lead-Acid/Gel) by setting the switch on the controller.

Connect the battery clamp extension to the panels. The Battery Clamps are colour coded; ...red for positive & black for negative.

System is reverse polarity protected. If the clamps are connected incorrectly nothing will happen & no damage will occur.



PLEASE NOTE – NO OUTPUT UNLESS THE UNIT IS CONNECTED TO A BATTERY OR DEVICE.

When the solar panel kit is first connected to a battery & exposed to the sun the charge controller must undertake a self – check program to ensure that it is operating correctly.

This program will take approx 3 minutes to complete and during this time the LED's on the charge controller will not be illuminated and the battery will not be receiving any charge, once the self-check is completed the system will engage and commence the charging process.

CAUTION – PLEASE NOTE:

1. Read & completely understand this instruction manual before use. Always keep this manual in a convenient location, a pocket is provided on the padded bag for the instruction manual.
2. To reduce the risk of injury, charge only 12V lead acid batteries, AGM & GEL batteries. Other types of batteries may be subject to bursting which can lead to personal injury & property damage. If uncertain about types and/or charging procedures contact the battery manufacturer.
3. Always use a well-ventilated space. Batteries emit explosive gases. These explosive gases can be ignited by a spark, cigarette or naked flame such as a cigarette lighter or matches.
4. Make sure the voltage of the battery being connected is the same as the output voltage of the solar controller.
5. Make sure to connect with correct polarity (positive pole to the positive pole, negative pole to the negative pole).
6. Battery must be removed from vehicle when connecting the solar controller to a vehicle's battery.
7. Keep away from explosive gases, flames, smoke & sparks.
8. Keep away from any flammable substances.
9. Always adhere to battery manufacture's recommendation when charging batteries.
10. Given sufficient light, solar panels always generate energy even when they are disconnected. Accidental 'shorting' of the terminals or wiring can result in spark causing personal injury or a fire hazard.
11. This unit is not intended for use by young children or infirm persons without supervision. Do not allow unsupervised young children to play with this unit.
12. Always avoid charging an old, damaged, overly discharged, defective battery.
13. When testing or working on or around a battery it is advisable to wear protective eye glasses.
14. Have plenty of fresh water & soap available in case battery acid comes into contact with skin, eyes or clothing.
15. If the battery acid makes contact with skin or clothing, flush immediately with large amounts of water. **In case of accidental eye contact with battery acid, flush eyes for at least 15 minutes with clean water. The eyes should be submerged under water & kept open. See a doctor immediately. Do not use eye drops or other medication unless instructed by a doctor.**
16. When working with a lead-acid type battery, be careful not to short-out the battery with a metal tool or object. Remove all personal items such as watches, rings, bracelets and necklaces. The possibility of a short circuit exists, which can damage such items & cause severe burns and/or personal injury.
17. Keep the surface of solar panels clean from dust & clean with a soft cloth. Do not walk on modules.
18. Avoid solar panel contact with water, acid or alkali.
19. Do not scratch or bend solar panels.
20. Do not disassemble or open the solar panels & the solar controller. There are no user-serviceable parts in this unit.
21. When mounting solar panels at a height adhere to all relevant safety regulations.
22. Do not pack heavy items on top the solar panels when storing or transporting.

TROUBLE-SHOOTING GUIDE

Please Note:

Solar panels & controller are maintenance-free.

There are no user-serviceable parts in this unit.

If you have any problems, please contact the supplier immediately.

The charge LED doesn't glow in yellow

Ensure the panels are exposed to sunlight.

Ensure all panel cables are free from damage & are connected correctly.

Ensure the cable from the controller to the battery are free from damage & connected correctly.

Check the battery voltage. If the battery voltage is less than 8V the controller will not work.

Check the fuse. The fuse will typically be blown for the following reasons:

- Battery poles +/- are reversed or a short circuit exists.
- Solar controller output current over 10A.

The charge LED doesn't glow in Green

Check battery voltage. Battery is most likely not fully charged.

Inspect & test the battery, checking the battery condition.

There is no voltage output reading from the panel

Check the output cables are connected to the battery correctly.

The panel must be connected to a battery or device for there to be a reading.

The SLP80F-12 is fitted with an SLC-1207 SMART controller that will not allow any output if the panel is not connected. This protects the solar panel.

FREQUENTLY ASKED QUESTIONS:

Q. How does the solar panel work?

A. The solar panel converts sunlight energy into DC electric power & can be used to charge a rechargeable battery.

Q. How many solar panels will it take to run my appliances?

A. As a general rule the user should establish the watts required to run the appliances & multiply them by the expected consumption hours.

Power Calculations:

$$\text{Power (Watts)} = \text{Current (Amps)} \times \text{Voltage (Volts)}$$

$$\text{Watt Hours} = \text{Watts} \times \text{Hours}$$

After completing these calculations the capacity of the solar panels can be established.

Example:

The following table represents a typical portable appliance configuration.

APPLIANCE	WATT	AMPS	HOURS	WATT HOURS	AMP HOURS
12V FLUORESCENT LIGHT	8	0.6	4	32	2.4
12V B&W TELEVISION	20	1.6	1	20	1.6
12V RADIO	5	0.4	1	5	0.4
12V FAN	4	0.25	5	20	1.25
12V TRAVEL IRON	120	10	1/6	20	1.67
12V FRIDGE	45	3.75	8	360	30
ESTIMATED CONSUMPTION				457	37.32

Power Load: 457 Watt Hours per Day

Assumption: Solar panel is exposed to 6 hours of suitable sunlight each day.

The required the solar panel would be 457 Watt Hours/6 Hours = 76.17 Watts.

In this example a 76.17 Watt panel is required to run the appliances for the desired time.

Q. How much battery capacity is required?

A. Solar power systems are generally sized to give plenty of reserve (autonomy) in the batteries. Power usage should only be 20% per day of your battery capacity.

Battery Capacity Calculation:

$$\text{Current (Amps)} \times \text{Hours} = \text{Amp Hour (Ah)}.$$

In the example above we have determined we required 37.32 Ah.

The minimum battery capacity recommended would be 186.6 Ah.