

Installation Guide

Communications Gateway

Communications Gateway

Installation Guide

About Schneider Electric

As a global specialist in energy management with operations in more than 100 countries, Schneider Electric offers integrated solutions across multiple market segments, including leadership positions in energy and infrastructure, industrial processes, building automation, and data centres/networks, as well as a broad presence in residential applications. Focused on making energy safe, reliable, and efficient, the company's 120,000 employees achieved sales of more than 17.3 billion euros in 2007, through an active commitment to help individuals and organisations “Make the most of their energy™”.
www.schneider-electric.com

About Xantrex

Xantrex Technology Inc. (www.xantrex.com), a subsidiary of Schneider Electric, is a world leader in the development, manufacturing and marketing of advanced power electronic products and systems for the renewable and mobile power markets. The company's products convert and control raw electrical power from any central, distributed, renewable, or backup power source into high-quality power required by electronic equipment and the electricity grid. Xantrex is headquartered in Vancouver, Canada, with facilities in the United States, Germany, Spain, and a joint venture in China.

Trademarks

Xantrex, **Xanbus**, and **Smart choice for power** are trademarks of Schneider Electric, registered in the U.S. and other countries.

Make the most of their energy is a trademark of Schneider Electric.

Other trademarks, registered trademarks, and product names are the property of their respective owners and are used herein for identification purposes only.

Notice of Copyright

Copyright © July 2009 Xantrex Technology Inc. No part of this document may be reproduced in any form or disclosed to third parties without the express written consent of:

Xantrex Technology Inc.
161-G South Vasco Road
Livermore, California USA 94551

Xantrex Technology Inc. reserves the right to revise this document and to periodically make changes to the content hereof without obligation or organization of such revisions or changes unless required to do so by prior arrangement.

Exclusion for Documentation

UNLESS SPECIFICALLY AGREED TO IN WRITING, XANTREX TECHNOLOGY INC. (“XANTREX”)

(A) MAKES NO WARRANTY AS TO THE ACCURACY, SUFFICIENCY OR SUITABILITY OF ANY TECHNICAL OR OTHER INFORMATION PROVIDED IN ITS MANUALS OR OTHER DOCUMENTATION;

(B) ASSUMES NO RESPONSIBILITY OR LIABILITY FOR LOSSES, DAMAGES, COSTS OR EXPENSES, WHETHER SPECIAL, DIRECT, INDIRECT, CONSEQUENTIAL OR INCIDENTAL, WHICH MIGHT ARISE OUT OF THE USE OF SUCH INFORMATION. THE USE OF ANY SUCH INFORMATION WILL BE ENTIRELY AT THE USER’S RISK; AND

(C) REMINDS YOU THAT IF THIS MANUAL IS IN ANY LANGUAGE OTHER THAN ENGLISH, ALTHOUGH STEPS HAVE BEEN TAKEN TO MAINTAIN THE ACCURACY OF THE TRANSLATION, THE ACCURACY CANNOT BE GUARANTEED. APPROVED XANTREX CONTENT IS CONTAINED WITH THE ENGLISH LANGUAGE VERSION WHICH IS POSTED AT WWW.XANTREX.COM.

Date and Revision

July 2009 Revision E

Part Number

975-0330-01-01

Product Number

865-1055 (North America), 865-1056 (Europe)

Contact Information

Telephone: 1 866 519 1470 (toll free North America)
1 650 351 8237 (direct)
+34 902 10 18 13 (Europe)

Fax: 1 604 422 2756 (direct)
+34 93 305 50 26 (Europe)

Email: customerservice@xantrex.com
support.europe@xantrex.com

Web: www.xantrex.com

About This Guide

Purpose

This Installation Guide provides explanations and procedures for installing and configuring the Communications Gateway.

Scope

The Guide provides safety guidelines and procedures for installing and configuring the Gateway. It does not provide detailed information about the underlying Xanbus™ or Modbus protocol.

Note: This manual documents features and operation of the Xantrex base model Gateway. Gateways installed by second-party service providers (OEMs) may incorporate modified features and functions that are not described in this manual.

Audience

The Guide is intended for anyone who needs to install and configure the Communications Gateway. Installers should be qualified electricians or service technicians. Once installed, the Gateway can be configured by a service technician or an end user.

Organization

This Guide is organized into three chapters and one appendix.

Chapter 1, “Introduction” contains information about the features and functions of the Communications Gateway.

Chapter 2, “Installation” contains information and procedures to install the Communications Gateway.

Chapter 3, “Configuration” contains information and procedures to configure the Communications Gateway.

Chapter 4, “Troubleshooting” contains reference information you can consult if you have problems using the Communications Gateway. This chapter also lists routers that have been tested with the Gateway.

Appendix A, “Specifications” contains electrical, mechanical and regulatory specifications for the Communications Gateway.

Conventions Used

The following conventions are used in this guide.



WARNING

Warnings identify conditions or practices that could result in personal injury or loss of life



CAUTION

Cautions identify conditions or practices that could result in damage to the unit or other equipment.

Important: These notes describe things which are important for you to know, but not as serious as a caution or warning.

Related Information

You can find more information about Xantrex Technology Inc. as well as its products and services at www.xantrex.com.

Important Safety Instructions



WARNING: Read and save these instructions

This Installation Guide contains important safety and operating instructions. Before using your Communications Gateway, be sure to read, understand, and save these safety instructions.



WARNING: Limitations on use

Do not use the Gateway in connection with life support systems, medical equipment, or where human life or medical property may be at stake.

General Precautions

1. Before installing and using this device, read all appropriate sections of this guide and any cautionary markings on the Gateway and the devices to which it connects.
2. Do not dismantle the Gateway; it contains no user serviceable parts.
3. Protect the Gateway from rain, snow, spray, and water.
4. Use only accessories recommended or sold by the manufacturer. Doing otherwise may result in a risk of fire, electric shock, or injury to persons.



WARNING: Shock and energy hazards

Connecting the Gateway to other equipment may require access to wiring compartments containing circuits that are shock and/or energy hazards. Refer to this manual and the manual provided with the other equipment, and to any warning or caution labels on the equipment. Be sure to disconnect all sources of power to the equipment before working near its wiring terminals.

Note that in some cases hazardous voltage may still be present at the input to the equipment, ahead of the disconnecting means. Any guards or barriers provided to prevent inadvertent contact with live parts must be left in place.

Protection Class III: All circuits in this product are non-hazardous Safety Extra Low Voltage when connected only to Xanbus or Ethernet networks. Connect only to the circuit recommended in this manual.

FCC Information to the User

This equipment has been tested and found to comply with the limits for a Class B digital device, pursuant to part 15 of the FCC Rules. These limits are designed to provide reasonable protection against harmful interference when the equipment is operated in a residential environment. This equipment generates, uses and can radiate radio frequency energy and, if not installed and used in accordance with the instruction guide, may cause harmful interference to radio communications. However, there is no guarantee that interference will not occur in a particular installation. If this equipment does cause harmful interference to radio or television reception, which can be determined by turning the equipment off and on, the user is encouraged to try to correct the interference by one or more of the following measures:

- Reorient or relocate the antenna.
- Increase the separation between the equipment and the receiver.
- Connect the equipment to a circuit different from that to which the receiver is connected.
- Consult the dealer or an experienced radio/TV technician for help.

This equipment contains a radio transmitter with the following ID numbers:

- FCC: R68WIPORT
- Industry Canada: 2867A-WIPORT

Wireless Networking Security

This device can be configured to connect to the Internet using wireless technology. As with all such devices, if you do not properly set up a wireless security system others can get unauthorized access to your Internet connection and possibly to personal information contained on your computer network.

Product Recycling



Do not dispose of this product with general household waste!

Electrical appliances marked with the symbol shown must be professionally treated to recover, reuse, and recycle materials, in order to reduce negative environmental impact. When the product is no longer usable, European consumers are legally obligated to ensure that it is collected separately under the local electronics recycling and treatment scheme.

Contents

Important Safety Instructions	vii
--	-----

1 Introduction

Gateway Overview	1-2
External Features	1-3
Types of Gateway Networks.....	1-5
Local Area Network	1-5
Gateway with Remote Access	1-7

2 Installation

Installing the Gateway	2-2
Choosing a Location	2-3
Materials and Tools Required	2-4
Supplied Materials	2-4
Other Materials and Tools	2-5
Mounting the Gateway	2-5
Connecting the Gateway to a Router or Computer	2-5
Connecting the Gateway to the Xanbus Network	2-6
Network Layout	2-8
Guidelines for Routing the Network Cables	2-8
Connecting the Gateway to a GT Inverter	2-9
Connecting the Gateway to a XW Hybrid Inverter/Charger	2-10
Verifying the Xanbus Network	2-11
Applying Power to the Gateway	2-11
Adding Devices to the Network	2-12
Installing Yahoo! Widgets	2-12

3 Configuration

Configuring the Gateway	3-2
Viewing the Configuration Web Page	3-2
Using the Solar Monitor Widget	3-3
Finding the Gateway IP Address Manually	3-5
Finding the Gateway IP Address with No Router in the System	3-8

- Using the Configuration Web Page ----- 3-9
 - Entering Your Basic Information ----- 3-10
 - Renaming Devices ----- 3-10
 - Configuring the Xanbus Baud Rate ----- 3-11
 - Configuring the Gateway for Your Network ----- 3-11
 - Configuring Wireless Mode ----- 3-13
 - Configuring Network Time ----- 3-15
 - Configuring Email ----- 3-18
 - Upgrading Device Firmware ----- 3-20
 - Upgrading the Gateway ----- 3-20
 - Upgrading Other Devices ----- 3-21
- Resetting the Gateway to Factory Defaults ----- 3-21
- Power System Monitoring on the Internet ----- 3-22

- 4 Troubleshooting**
 - Device Discovery ----- 4-2
 - Loss of Communication ----- 4-3
 - Email Messages ----- 4-4
 - Miscellaneous Issues ----- 4-5
 - Router Compatibility ----- 4-6

- A Specifications**
 - Electrical Specifications ----- A-2
 - Communication Specifications ----- A-2
 - History Data Storage ----- A-2
 - Mechanical Specifications ----- A-3
 - Environmental Specifications ----- A-4
 - Regulatory Compliance ----- A-4

- Warranty and Return Information ----- WA-1**

- Index ----- IX-1**

1

Introduction

Chapter 1, “Introduction” contains information about the features and functions of the Communications Gateway.

This chapter covers the following topics:

- “Gateway Overview”
- “External Features”
- “Types of Gateway Networks”

Gateway Overview

The Communications Gateway is the central component for a residential power monitoring system. The Gateway communicates with Xantrex GT Solar Inverters and XW Hybrid Inverter/Chargers and transmits a unified view of system performance to a computer-based power monitoring application.



On one side, the Gateway directly communicates with a Xantrex inverter using Xanbus™, a CAN-based network communication protocol developed by Xantrex. The Gateway converts Xanbus messages to Modbus messages, and transmits the converted inverter performance data for monitoring. On the other side, the Gateway’s Wi-Fi/Ethernet module provides an interface to monitor system performance on a personal computer. Computer-based monitoring can be performed on your Local Area Network or using the Internet from any location.

The Gateway features include a standard plug-in Wi-Fi/Ethernet module with 10/100 Base-T or 802.11b/g, and:

- Embedded web services to support Yahoo! Widgets. Xantrex provides a Solar Monitor Widget to display data transmitted by the Gateway.
- Embedded web page for configuring the Gateway and upgrading device firmware.

The Gateway logs and transmits performance data such as:

- Power system energy production
- Individual inverter energy production
- Energy production history—daily, weekly, monthly
- Xanbus device faults.

To view this production data, you must install the Xantrex Solar Monitor Widget and configure the Gateway to communicate with your computer or computer network. Other means of viewing Gateway-transmitted data will be available from Xantrex in the future. For more information about Gateway data storage, see “History Data Storage” on page A–2.

Note: The Gateway provides performance data only from the time it is connected to your power system. The Gateway cannot be calibrated to match existing power production totals for a power system that has been operating without a Gateway. When connected to an existing power system, the Gateway power production totals will differ from the totals displayed by older inverters or devices in the system.

External Features

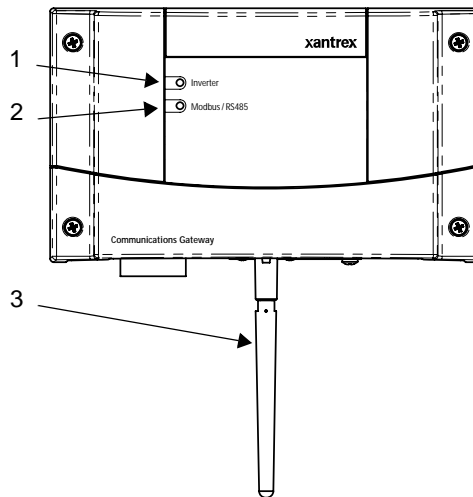

Figure 1-1 Gateway Front

Item	Description
1	<p>Inverter LED indicates overall status of the network between the Gateway and the inverters. The LED blinks in three colors:</p> <ul style="list-style-type: none"> • Green: the network is working properly • Yellow: the Gateway has detected errors on the network • Red: the Gateway has stopped communicating in the network.
2	<p>Modbus/RS485 LED indicates message transmission between the Gateway and an Internet protocol-connected computer. The LED blinks during regular operation. The LED is on steadily when the Gateway is upgrading device software or the Gateway is in bootloader mode and requires its own software to be loaded. See “Upgrading Device Firmware” on page 3–20.</p>
3	<p>Antenna for the wireless Internet protocol connection.</p>

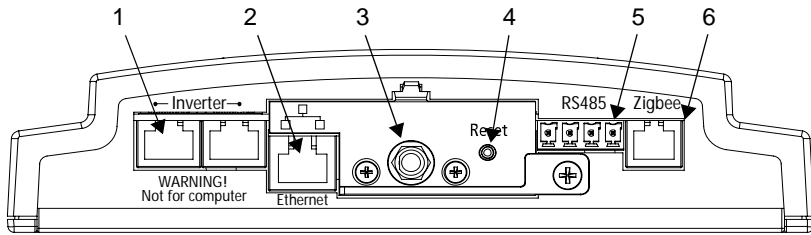

Figure 1-2 Gateway Bottom

Item	Description
1	Inverter (Xanbus RJ-45) ports for connecting the inverter and other Xanbus devices to the Gateway. Caution: see “Equipment damage” below.
2	Ethernet port for connecting the Gateway to a router or computer. Caution: see “Equipment damage” below.
3	Wi-Fi Antenna.
4	Reset button. The Reset button returns the Gateway to its default settings. See “Resetting the Gateway to Factory Defaults” on page 3–21.
5	RS-485 port for connecting Modbus-equipped devices (reserved for future use).
6	Zigbee (RJ-11) port (do not use—not supported at this time).



CAUTION: Equipment damage

Although the cables and connectors that connect the Gateway to the Xanbus network are identical to Ethernet cables and connectors, the communication interface is not Ethernet. It is based on CAN bus and also supplies the Xanbus network devices with DC power. The DC power in the Xanbus network is not compatible with Ethernet. Personal computers or routers may be damaged if connected directly to powered Gateway Inverter ports. The Gateway can be damaged if a powered Xanbus cable is connected to the Ethernet port.

Types of Gateway Networks

The Gateway can interface with different devices with wired or wireless connections to provide several options for monitoring your power system performance.

Local Area Network

The Gateway provides performance data for display on a home computer. Data is displayed using the Solar Monitor Widget, available free from Xantrex.

Connections between the Gateway, router and computer can be wired or wireless, but not both at the same time. An Ethernet connection between the Gateway and router or computer is required for initial installation and configuration, after which the Gateway can be set to wireless mode and the cable removed.

Note: The following illustrations show the Gateway connected to a single GT Inverter. When the Gateway is connected to a single GT Inverter, a separate Xantbus power supply (not shown) is required.

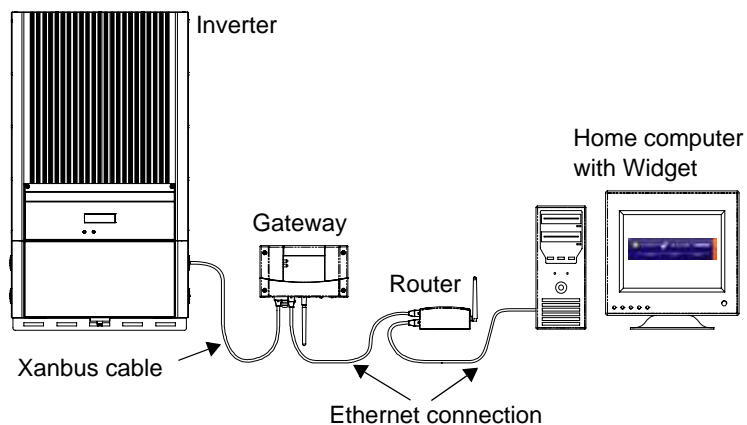

Figure 1-3 Default Wired Network

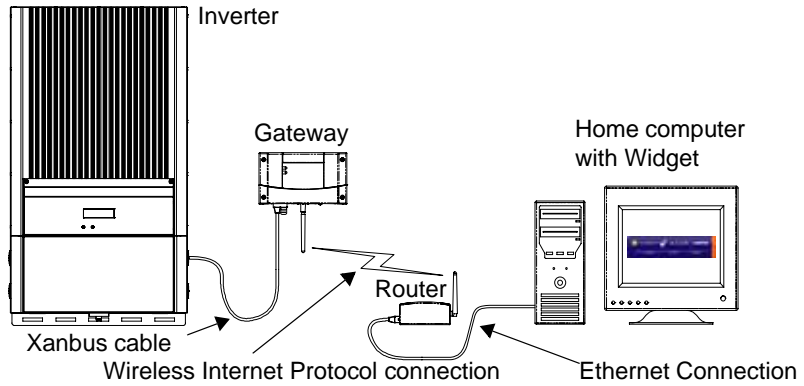

Figure 1-4 Mixed Wired/Wireless Network 1

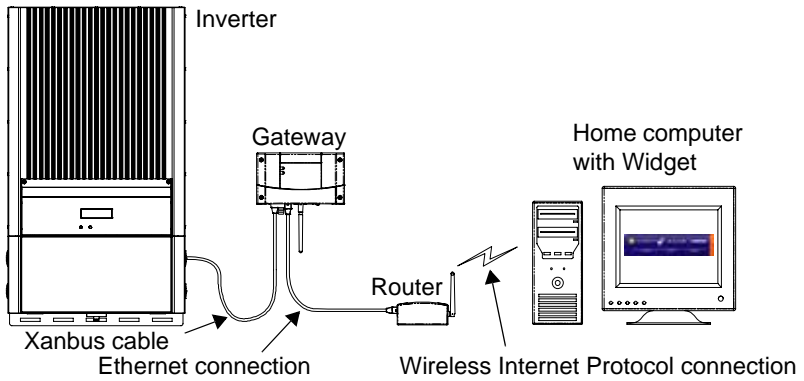

Figure 1-5 Mixed Wired/Wireless Network 2

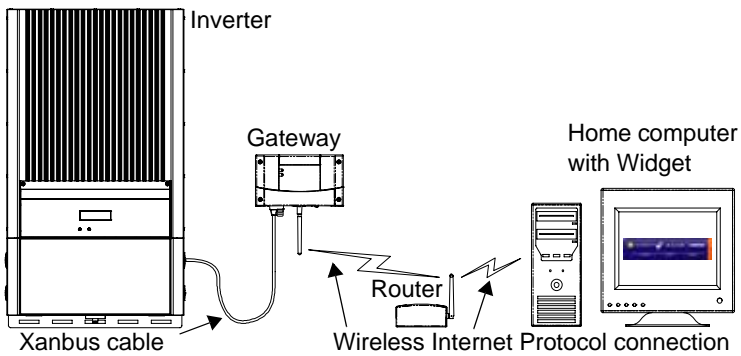

Figure 1-6 Wireless Network With Router

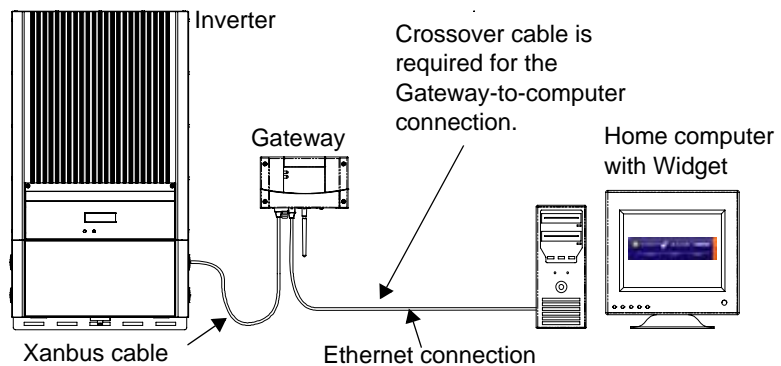

Figure 1-7 Wired Network Without Router

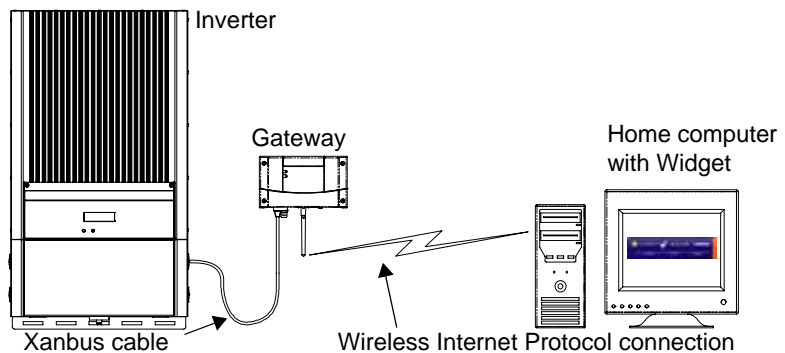

Figure 1-8 Wireless Network Without Router

Important: Figure 1-7 and Figure 1-8 are “Ad-Hoc” networks that do not allow access to the Internet. For more information, see “Configuring Wireless Mode” on page 3–13.

Important: The wired connections shown in Figure 1-3, Figure 1-5 and Figure 1-7 are required for initial system configuration.

Gateway with Remote Access

To view power system performance data on a remote computer using the Internet from any location, you must connect the Gateway to a router and change your router firewall settings to allow “port forwarding.” Port forwarding enables a computer from an external IP address (elsewhere on the Internet) to view Gateway data. Port forwarding allows you to specify

how and where Gateway data is directed through your router so that you can view that data from an Internet-connected computer anywhere in the world.

For more information, see the Gateway configuration web page (“Viewing the Configuration Web Page” on page 3–2) and “Power System Monitoring on the Internet” on page 3–22.

If you simply want to monitor your power system on your home network, you do not need to change your firewall settings.



CAUTION: Computer Security Risk

Changing your router’s firewall settings to allow port forwarding can potentially leave your home network open to attacks from external computers. Do not change your firewall settings unless you are absolutely sure of how to do it correctly. The PORT Forward web site (www.portforward.com) has collected information on how to configure most popular routers. Xantrex does not provide any guarantees as to the security of your network if you follow the advice provided at the PORT Forward web site. Use at your own risk.

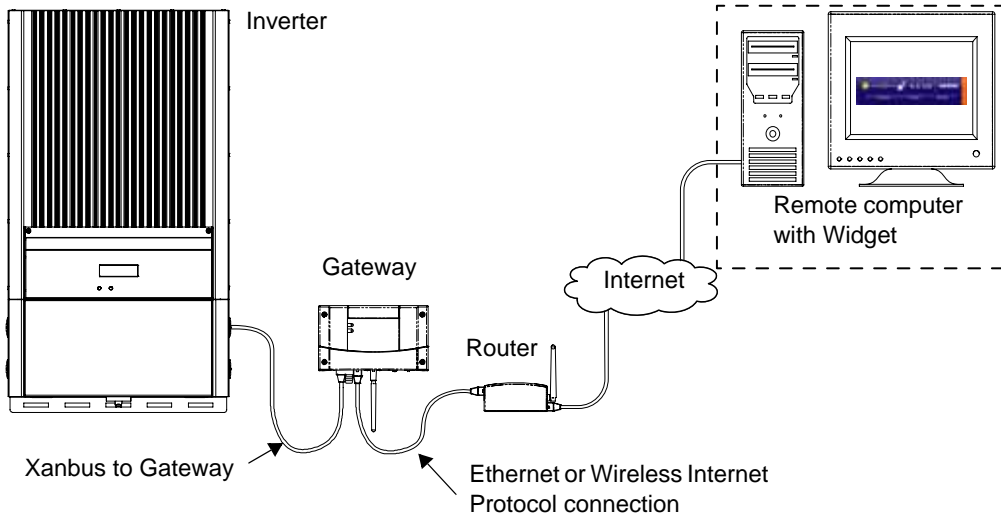

Figure 1-9 Gateway with Widget and Remote Access

2

Installation

Chapter 2, “Installation” contains information and procedures to install the Communications Gateway.

Gateway installation includes mounting the Gateway, then connecting it to a computer network and to the Xanbus network.

Installing the Gateway



WARNING: Shock and energy hazards

Connections to other equipment may require accessing wiring compartments containing circuits that are shock or energy hazards. In such cases, ensure that sources of power are disconnected. Installation should be done only by a qualified installer or electrician.

This chapter assumes that one or more inverters are already installed, and that multiple inverters are already connected with network cables. For more information about installing a multiple-inverter network, see:

- For GT Inverters: “Communications Wiring for Multiple Inverters” in the *Solar Inverter Owner’s Manual*
- For XW Hybrid Inverter/Chargers: *The XW Power System Installation Guide*.

Installing the Gateway consists of the following steps:

1. Choosing a location.
2. Mounting the Gateway.
3. Connecting the Gateway to a router (your local area network) or computer.
4. Connecting the Gateway to the Xanbus network.

Connecting the Gateway to the Xanbus network also applies power to the Gateway.

Important: Apply power to the Gateway only after connecting it to the local area network in the previous step. This ensures that the Gateway can acquire an IP address quickly, and does not first acquire a default address that it must reject after a time-out period.

5. Installing Yahoo! Widgets (also known as Konfabulator or Yahoo! Widget Engine) and Solar Monitor Widget on your computer.
The Solar Monitor Widget displays power system performance data transmitted from the Gateway.

Choosing a Location

Choose a clean, dry, easily accessible location. Indoor installations are recommended. For outdoor installations, mount the Gateway inside a weatherproof enclosure.

Minimum clearance

To comply with FCC and Industry Canada regulations, the Gateway must be installed in a location where the antenna is at least 200 mm (8 inches) away from people and any other antenna.

Maximum distance between devices

Distance and orientation are important factors to consider when installing a wireless network. In testing, the Gateway has delivered acceptable performance under optimal conditions up to 90 meters (300 feet) away from another wireless device. Many factors can affect network performance, including house construction, antenna orientation, and distance between devices.

For best performance, a wired Ethernet connection between the Gateway and the Internet router is recommended.

Important: During Gateway configuration, you must connect the Gateway to the router or computer with an Ethernet cable. After the Gateway has established network connections, you can configure the Gateway for wireless mode, after which you can remove the cable between the Gateway and the router.

Table 2-1 Distances Between Gateway and Router

Connection Type	Maximum Distance (Approximate)	
	Wired	Wireless
Gateway to Router	60 m (200 ft)	90 m (300 ft)

Table 2-2 Total Xanbus Network Length

Xanbus Baud Rate ^a	Total Xanbus Network Length
250 kbps	40 m (130 ft)
125 kbps	300 m (1000 ft)

a.The 125 kbps baud rate only applies to GT inverters.

Important: By default, the Xanbus baud rate is set to 250 kbps for North American models and 125 kbps for European models. If you have a GT inverter and want to change the baud rate, make sure to follow the recommended procedure supplied by Xantrex. See the Application Note, “Xantrex Grid Tie Solar Inverter Baud Rate Change Procedure” (976-0216-01-01 available on www.xantrex.com).

Important: When creating long Xanbus networks (i.e. greater than 100 m), you must verify network integrity using a CANbus network analysis tool such as the Maretron N2KMeter Diagnostic Tool for NMEA2000 compatible networks. See “Verifying the Xanbus Network” on page 2–11.

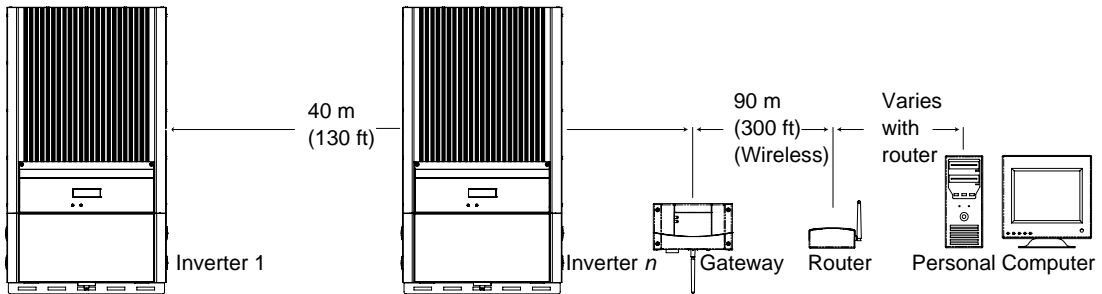

Figure 2-1 Maximum Distances Between Devices (250 kbps Xanbus baud rate)

Materials and Tools Required

The following materials and tools are required to install the Gateway.

Supplied Materials

- Gateway
- 10 ft (3 m) Xanbus network cable (standard straight-through Ethernet cable—CAT 5e)



CAUTION: Equipment damage

Do not use crossover cable for the Xanbus network cable. On crossover cable, the order of color-coded wires at each end of the cable is different.

- Four #6 screws
- Network terminators (supplied with the Gateway and the inverter).

Other Materials and Tools

- Additional Ethernet cable (for connecting the Gateway to a router) or crossover cable (when connecting the Gateway directly to a computer)
- Xanbus power supply (required when connecting the Gateway to a single GT Inverter)
For a network power supply, contact Xantrex at 1 800 670-0707 or customerservice@xantrex.com.
- Weatherproof enclosure (if installing the Gateway outdoors)
- Phillips screwdriver
- Power drill
- Cable clamps or hardware fasteners.

Mounting the Gateway

Indoors

Mount the Gateway on a wall with the connectors facing downwards. For Gateway dimensions, see Figure A-1 on page A-3.

To mount the Gateway:

1. Hold the unit flush and square against the wall, panel, or horizontal surface.

If the mounting surface requires pre-drilled holes for the screws, use the supplied mounting template to mark, then drill, four holes.

2. With a Phillips screwdriver and the supplied #6 screws, secure each corner of the Gateway to the mounting surface.

Outdoors

Outdoor Gateway installations require the Gateway to be mounted inside a weatherproof enclosure.

Connecting the Gateway to a Router or Computer

Important: During setup, a wired connection between the Gateway and the router is required. During configuration, the Gateway can be switched to wireless mode and the network cable can be removed. See “Configuring Wireless Mode” on page 3-13.

To connect the Gateway to a router:

- ◆ Connect a standard Ethernet cable from the Gateway Ethernet port to an open network port on your router.

Do not connect the Gateway to the router port labeled “Internet” or “WAN.”

To connect the Gateway directly to a computer:

- ◆ Connect a crossover cable from the Gateway Ethernet port to an open network port on your computer.

Connecting the Gateway to the Xanbus Network

Important: Connecting the Gateway to the Xanbus network also applies power to the Gateway. Before making the final connection to the Gateway, see “Applying Power to the Gateway” on page 2–11.

A Xanbus network consists of the following components:

- Xanbus-enabled devices—these include the Gateway, the GT Inverter, the XW Series Inverter/Charger, XW Automatic Generator Start (AGS), System Control Panel (SCP), and XW Charge Controller. The maximum number of devices on the network depends on the type of device. For example, the Gateway can monitor a network consisting of up to 20 GT Inverters (up to five GT Inverters if a GT Solar Inverter Monitor is installed) or an XW Power System with up to three XW Inverter/Chargers, two Charge Controllers, an AGS, SCP, and Gateway. (This is the current maximum size of an XW Power System. Future XW releases will allow more than three XW Series Inverter/Chargers to operate in a Xanbus network.)

In systems that combine GT and XW inverters, treat an XW Series Inverter/Charger as the equivalent of four GT Inverters. XW inverters transmit up to four times as much network data as a GT Inverter.

- Xanbus power supply—the inverter or inverter/charger provides network power.

Important: If the Gateway is connected to a single GT Inverter, an external Xanbus power supply must be added to the system. XW Hybrid Inverter/Chargers or any multiple GT Inverter installation can provide sufficient network power.

- Xanbus cables—each Xanbus-enabled device is connected by a standard Ethernet (CAT 5e) cable. A 10 foot (3 meter) network cable is included with the Gateway. If more cables or a different length are required, these standard cables can be purchased from Xantrex or any computer supply store.

**CAUTION: Equipment damage**

Do not use crossover cable. On crossover cable, the order of color-coded wires at each end of the cable is different.

- Network terminators (Figure 2-2)—the Xanbus network must be properly terminated at each end with network terminators. If the network is not properly terminated, signal quality is degraded and performance on the network is reduced. Permanent configuration without terminators is not supported by Xantrex. One terminator is included with the Gateway. Depending on your network layout, this terminator may need to be inserted into another device elsewhere in the network.

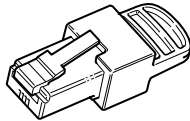

Figure 2-2 Network Terminator

Network Layout

Xanbus-enabled devices are linked with separate lengths of Xanbus cable, as shown in Figure 2-3.

To ensure communication signal quality, each end of the network must be terminated. The Xanbus-enabled devices at each end of the network must have a male terminator inserted into their open network ports.

If the Gateway is the last device on the network, the open Inverter port on the Gateway must be terminated. See Figure 2-3.

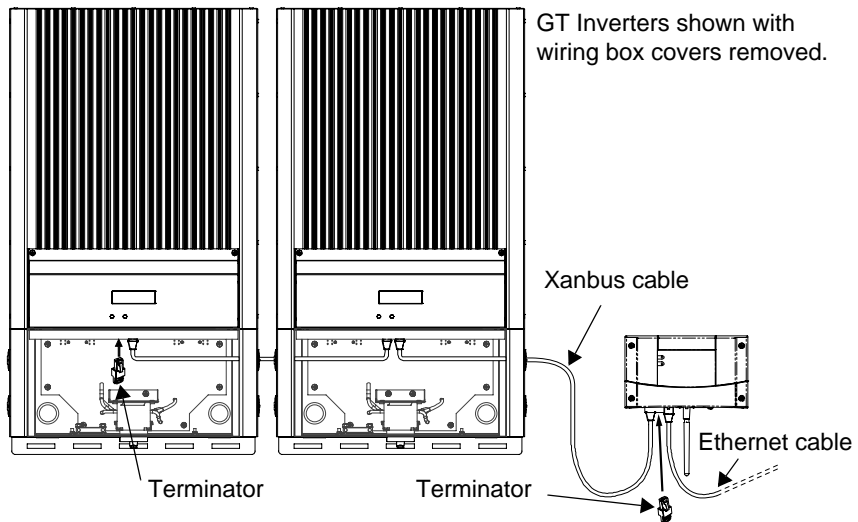

Figure 2-3 Network Layout Diagram

Guidelines for Routing the Network Cables



WARNING: Shock hazard

Do not route the network cables in the same conduit as the AC and DC power cabling. When connecting and routing the network cable in the inverter wiring box, make sure the network cable is physically separated from the AC and DC power cables and any bare live parts by a barrier or by wire routing and securing means.

To ensure maximum performance of your network, follow these guidelines when routing the network cables.

- Route the cables away from sharp edges that might damage the insulation.

- Allow for some slack in the cable tension.
- Do not staple the cable outside the inverter with metal cable staples. Use the appropriate hardware fasteners to avoid damage to the cable.

**CAUTION: Unpredictable network operation**

Do not exceed the maximum total Xanbus network length shown in Table 2-2, “Total Xanbus Network Length” on page 2–3. Proper network operation cannot be guaranteed when these distances are exceeded.

**CAUTION: Unpredictable device behavior**

Do not connect one end of the network to the other to make a ring or loop.

**CAUTION: Equipment damage**

Although the cables and connectors that connect the Gateway to the Xanbus network are identical to Ethernet cables and connectors, the communication interface is not Ethernet. It is based on CAN bus and also supplies the Xanbus network devices with DC power. The DC power in the Xanbus network is not compatible with Ethernet. Personal computers or routers will be damaged if connected directly to powered Gateway Inverter ports. The Gateway can be damaged if a powered Xanbus cable is connected to the Ethernet port.

Connecting the Gateway to a GT Inverter

The GT Inverter is equipped with two Xanbus (RJ-45) network ports inside the wiring box. See Figure 2-4. Follow the guidelines for connecting devices and terminating the network as described in “Network Layout” on page 2–8, and in “Communications Wiring for Multiple Inverters” in the *GT Inverter Owner’s Manual*.

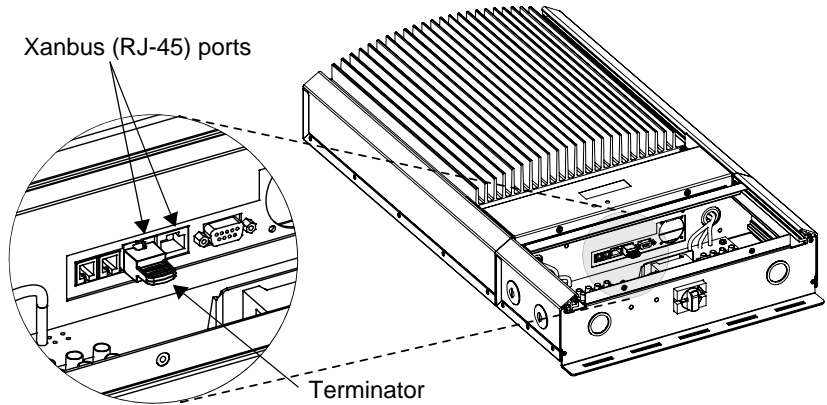

Figure 2-4 GT Inverter Xanbus (RJ-45) Ports

Connecting the Gateway to a XW Hybrid Inverter/Charger

The XW Hybrid Inverter/Charger is equipped with two Xanbus network ports (see Figure 2-5). These ports may not be immediately accessible if a conduit box is installed on the bottom of the inverter/charger. Follow the guidelines for connecting devices and terminating the network as described in “Network Layout” on page 2–8, and in “Xanbus Network Installation” in the *XW Power System Installation Guide*.

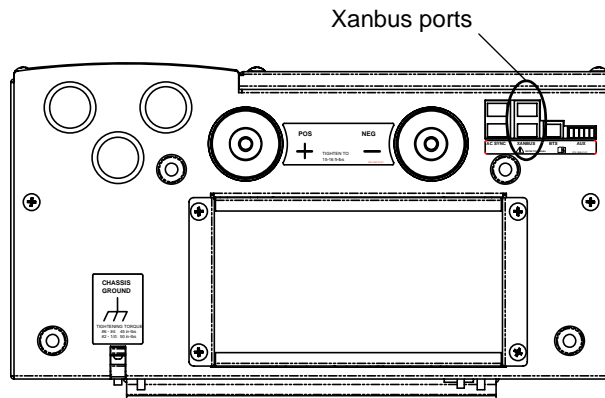

Figure 2-5 XW Inverter/Charger Xanbus Ports

Verifying the Xanbus Network

For long Xanbus networks (greater than 100 m), you must verify network integrity using a CANbus network analysis tool such as the Maretron N2KMeter Diagnostic Tool for NMEA 2000 compatible networks. To determine if the network is healthy, check to see if any bus errors are present on the network. The presence of bus errors, specifically more than one bus error per second, indicates that the network is not operating optimally.

If the CANbus analyzer indicates your network is not operating properly, check the following and then re-test the network.

- Make sure the total Xanbus network length has not been exceeded. See Table 2-2, “Total Xanbus Network Length” on page 2–3.
- Make sure the network has only two terminators installed – one at each far end of the network.
- Make sure there are no long stub connections coming from a Xanbus 3-port T connector (if any are used). Daisy chain network configuration is the optimal configuration.
- Make sure all cable sections are correct and not shorted anywhere.

Applying Power to the Gateway

The Gateway gets its power from the Xanbus network through the network cable. When applying power to the Gateway by connecting the network cable, ensure that the Xanbus network itself has power. The inverter or inverter/charger supplying power to the Xanbus network must be operating.

If connecting the Gateway to a GT Inverter, ensure that the GT Inverter DC/AC disconnect switch is in the ON position. The GT Inverter LCD should be on.

If connecting the Gateway to an XW Hybrid Inverter/Charger, ensure that the inverter/charger is operating. The Inverter Information Panel should be illuminated.

To apply power to the Gateway:

- ◆ Plug the Xanbus network cable from the network into an Inverter port on the Gateway.

After connecting the Gateway to the Xanbus network, the Gateway performs a power-up test. The Inverter LED lights up green for 1 second, the Modbus LED lights up yellow for 1 second, then the Inverter LED lights up red 1 second. During normal operation the Inverter LED blinks green and the Modbus LED blinks occasionally.

The Inverter LED blinks green if the Xanbus network is working properly. It blinks yellow or red if there is a problem with the network. The Modbus LED flashes when an external device requests data from the Gateway.

Adding Devices to the Network

The Xanbus network is expandable. Before installing additional inverters or other network devices, follow these guidelines.

- Close the Solar Monitor Widget if it is running. If the Widget detects a device dropping off the network due to a disconnected network cable, it issues an error message.
- Remove network power from the Gateway by unplugging the Xanbus network cable from the Gateway.
- Do not apply power to the Gateway until the new network devices are completely connected.

Installing Yahoo! Widgets

The files and procedures described in this section are also available from the Quickstart Guide on the CD supplied with the Gateway.

To run the Solar Monitor Widget, you must first install Yahoo! Widgets (also known as Konfabulator or Yahoo! Widget Engine). Open your web browser and go to <http://widgets.yahoo.com/>. Follow the instructions for downloading Yahoo! Widgets.

Operating Systems Supported (as of the first release of the Gateway):

- Windows XP SP2, 2000 SP4
- Windows Vista
- Mac OS X 10.3.9 and up.

Yahoo! recommends:

- Connection to the Internet
- 512 megabytes of RAM.

After installing Yahoo! Widgets, install the Xantrex Solar Monitor Widget.

To install the Solar Monitor Widget:

1. Select and copy the xtSolarMonitor-xx.xx.widget file on the supplied CD. The Widget file is in the _Widget folder.

You can also go to www.xantrex.com/gateway and download the latest version of the Widget.

2. Paste the .widget file to the My Widgets folder. This folder is in My Documents (Windows XP) or Documents (Vista).

For information about starting and using the Solar Monitor Widget, see the Solar Monitor Widget User Guide, available on the CD supplied with the Gateway.

3

Configuration

Chapter 3, “Configuration” contains information and procedures to configure the Communications Gateway.

This chapter includes the following topics:

- “Configuring the Gateway”
- “Viewing the Configuration Web Page”
- “Using the Configuration Web Page”
- “Resetting the Gateway to Factory Defaults”
- “Power System Monitoring on the Internet”

Configuring the Gateway

You can configure the Gateway using a web page embedded in the Gateway firmware. This web page allow you to configure parameters for:

- basic networking
- wireless networking
- network time protocol
- email messages for energy harvest and system performance.

You can also use the configuration web page to upgrade firmware for network devices, including the Gateway.

The configuration web page itself has extensive embedded help. This chapter contains additional information and advice.

Viewing the Configuration Web Page

To view the configuration web page, you must find the device IP address of your Gateway. The easiest way to find the Gateway on your network is to run the Solar Monitor Widget after applying power to the Gateway. The Widget has an automatic device discovery feature that functions on most computers and small home-based computer networks. After the device discovery process finds the Gateway, you can use the Widget to view the Gateway configuration web page. See “Using the Solar Monitor Widget” on page 3–3.

If you have multiple Gateways installed on the same network, the device discovery process attempts to locate them all. You can use the Widget to check which Gateways have been located (see the *Solar Monitor Widget User Guide*). If the device discovery process does not work for one or more Gateways, you must find and assign the Gateway IP addresses manually. See “Finding the Gateway IP Address Manually” on page 3–5.

Computers operating on a company domain (not a home workgroup) often have the device discovery disabled for security reasons. If this is the case, you will have to manually determine the Gateway’s IP address in order to view the configuration web page.

Software firewalls, such as ZoneAlarm or Windows Firewall, may also prevent device discovery from running. If possible, add the device discovery process to the firewall’s exception list so that it is allowed to function. If you can’t add device discovery to the exception list, you will

have to manually determine the Gateway's IP address in order to view the configuration web page. See "Finding the Gateway IP Address Manually" on page 3–5.

Using the Solar Monitor Widget

After installing the Yahoo! Widgets and copying the Solar Monitor Widget from the CD, you should have a Yahoo! Widgets icon on the right side of your Windows taskbar. This icon provides several options for running and viewing Yahoo! Widgets.

Important: If you are connected to a virtual private network (VPN), ensure that you disconnect the VPN before starting the Widget. Connection to a VPN prevents the automatic device discovery process between the Communications Gateway and the Widget.

To start the Widget for the first time:

1. Right click the Yahoo! Widgets icon.



2. Click **Preferences...**, select **Consolidate Widgets**, then click **Save**.
Selecting **Consolidate Widgets** ensures that all new Widgets move to the My Widgets folder after startup.
3. Double click the Solar Monitor Widget file (xtSolarMonitor-xx.xx.widget) you copied from the CD.

The Widget opens and requests a password.



Figure 3-1 Widget Password Screen

4. In the password box, type a lower-case "x" and press Enter.

The Widget displays the message “Authenticating...,” then the Main Status Window appears. If a device in the system has a fault, the Widget displays Component Details. The device with the fault is listed in Component Details.

If the Widget does not discover the Gateway after five attempts and displays “Lost Communication,” automatic device discovery did not work. See “Finding the Gateway IP Address Manually” on page 3–5.



Figure 3-2 Widget Main Status Screen

To view the configuration web page using the Solar Monitor Widget:

1. With the Gateway powered and connected with an Ethernet cable to your home network, start the Solar Monitor Widget.
2. Wait for the Widget to contact the Gateway and enter the password (the default password is “x”).

The main status screen appears.

3. On the Widget, click **Details**.

The Details drawer extends.



Figure 3-3 Widget Details Drawer

4. Under Component Details, click **Gateway**. (The Gateway IP address is listed to the right of the Gateway name.)

Your web browser opens.

5. If a password prompt appears, enter the password (the default password is “x”) and click **Sign in**.

The configuration web page opens.

6. Follow the guidelines on the configuration web page for configuring the Gateway.

Finding the Gateway IP Address Manually

To view the configuration web page on a protected domain:

1. Open your web browser and enter your router's IP address into the Address bar. Check your router documentation if necessary. Usually this address is 192.168.0.1 or 192.168.1.1, unless it was changed when the router was installed.

The router log-in page appears.

2. Enter your user name (usually "admin") and password. Check your router documentation if necessary.
3. Navigate to the router page that lists all devices connected to your router. For example, on the Linksys WRT300N router this can be accessed under "Status—Local Network" then by clicking on "DHCP Client Table." Other routers may list devices under "Hostname." Some routers do not show this information at all. If that is the case, follow the directions in "Finding the Gateway IP Address with No Router in the System" on page 3–8.
4. The router page should list your computer name and "POWERSYSTEM" (the default Gateway name) along with an IP address for each. In Figure 3-4, the Gateway IP address is 192.168.7.101. Note that this address can change for several reasons, including turning your router on and off, or disconnecting and reconnecting devices to your router.

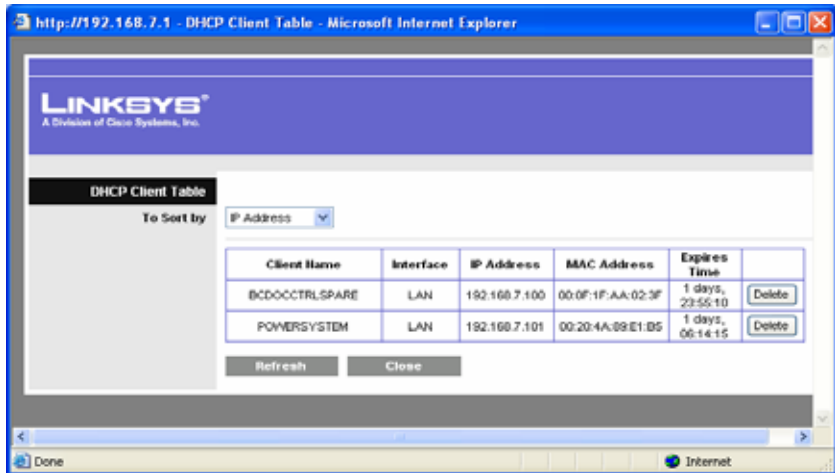

Figure 3-4 Finding the Gateway IP Address

5. Write down or select and copy the Gateway IP address.
6. Start the Widget and right-click it to view the Widget preferences.
7. Under **Comm** in Widget Preferences, clear the **Auto-detect Device** check box.

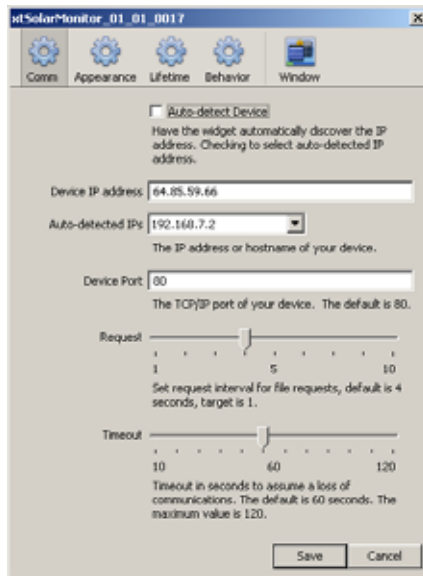

Figure 3-5 Widget Comm Preferences

8. In the **Device IP address** box, enter the Gateway IP address.
9. Click **Save**.
10. On the Widget, click **Details**.

The Details drawer extends.



Figure 3-6 Widget Details Drawer

11. Under Component Details, click **Gateway**.
Your web browser opens.
12. If a password prompt appears, enter the password (the default password is “x”) and click **Sign in**.
The configuration web page opens.



Figure 3-7 Gateway Configuration Web Page

Finding the Gateway IP Address with No Router in the System

If the Gateway is connected directly to your computer, or if your router cannot display the IP addresses of devices connected to it, you can use the application DeviceInstaller™ supplied by Lantronix™ at www.lantronix.com.

Enter the name “DeviceInstaller” into the search box on the Lantronix home page, and follow the links to download the application. You may need to install Microsoft.NET Framework, which is available at the same site.

When running DeviceInstaller, a search button in the toolbar can usually find devices with embedded Lantronix products (such as the Gateway) when nothing else will work.



CAUTION: Equipment damage

Use DeviceInstaller only to search for the Gateway IP address. Other functions provided by the program can damage your Gateway.

Using the Configuration Web Page

The configuration web page is divided into the following sections:

- Welcome—an introduction to the Gateway and the configuration web page.
- Home—entering your basic information, changing the password, renaming inverters and other devices on the network, and configuring the Xanbus baud rate. See:
 - “Entering Your Basic Information” on page 3–10
 - “Renaming Devices” on page 3–10
 - “Configuring the Xanbus Baud Rate” on page 3–11
- Network Configuration—configuring network parameters. See “Configuring the Gateway for Your Network” on page 3–11.
- Wireless Configuration—configuring the Gateway to operate in wireless mode. See “Configuring Wireless Mode” on page 3–13.
- Time Configuration—configuring network time protocol parameters. See “Configuring Network Time” on page 3–15.
- Mail Configuration—selecting and configuring email sent by the Gateway. See “Configuring Email” on page 3–18.
- Upgrade Device—upgrade the firmware of any Xantrex network-enabled device in the system. “Upgrading Device Firmware” on page 3–20.

Important: Set Network and Wireless Configuration first. If the Gateway loses connection with your computer or LAN due to a mis-configuration of network or wireless settings, you must reset the Gateway to re-establish an Ethernet connection. See “Resetting the Gateway to Factory Defaults” on page 3–21. Because resetting the Gateway erases your configuration in progress, you should first attempt to configure network and wireless parameters before entering any other information. Once network and wireless parameters are configured properly, configuring other fields will not cause any loss of connection with your computer or LAN.

Entering Your Basic Information

Click **Home** and enter your name, phone number and email address. The Gateway includes this information in the “From:” line in any email the system automatically generates. In this way, customer care and installers will be better able to contact you if a service-related issue arises.

Important: If you do not enter this basic information, the Gateway sends email with “unknown sender” in the “From:” line.

Gateway Test To verify Gateway functionality, click **Submit**. If the test is successful, the message “Ping Good, Test Good” appears.

Changing the password

To change the password from the default “x”:

1. In Old Password, enter the current password.
2. In New Password, enter the new password you would like to have. Select a secure password by including at least one number and one non-numeric character.
3. Enter the new password again to confirm it.
4. Click **Change Password**.

Renaming Devices

To rename an inverter or another device:

1. In the Select Device list, click the device you want to rename.
2. In New Device Name, type a new name for the device.
Device names are limited to 15 characters. The Gateway also adds a three-digit extension to all device names.
3. Click **Change Device Name**.

You can change the device name here. It is recommended that the new device name is unique within the system.

The screenshot shows a web interface for renaming a device. At the top, there is a text instruction: "You can change the device name here. It is recommended that the new device name is unique within the system." Below this, there are three main elements: a "Select Device" dropdown menu currently showing "Inverter 101", a "New Device Name" text input field, and a "Change Device Name" button.

Figure 3-8 Changing a Device Name

Configuring the Xanbus Baud Rate

You can change the Xanbus baud rate for Xantrex Grid Tie Solar Inverters. Possible values are 250 kbps and 125 kbps.

Important: Devices operating on the same bus must have the same baud rate. You cannot operate devices with different baud rates on the same bus.

Important: Remote upgrade using the Gateway is not supported on systems with a 125 kbps baud rate. If you change the baud rate to 125 kbps, then you will no longer be able to use the Gateway to upgrade the firmware on GT inverters. You will have to upgrade each inverter in the system using an RS-232 cable and a laptop.

You cannot change the baud rate for XW system devices and components.

Important: By default, the Xanbus baud rate is set to 250 kbps for North American models and 125 kbps for European models. If you have a GT inverter and want to change the baud rate, make sure to follow the recommended procedure supplied by Xantrex. See the Application Note, “Xantrex Grid Tie Solar Inverter Baud Rate Change Procedure” (976-0216-01-01 available on www.xantrex.com).

To change the baud rate:

1. Click **Home**.
2. Select the new value from the Xanbus Baud Rate drop-down list. See Figure 3-9.
3. Click **Change Baud Rate**.

You can change Gateway's Xanbus baud rate (kbps) here. The factory default is 250 (kbps).

Xanbus Baud Rate 

Figure 3-9 Changing the Baud Rate

Configuring the Gateway for Your Network

Click **Network Configuration** to configure the Gateway with basic networking parameters. If you already have a network, you should be able to copy some of these values from some of your existing equipment.

You will need to configure Gateway networking parameters to enable power monitoring from any location via the Internet. For more information, see “Power System Monitoring on the Internet” on page 3–22.

MAC Address Shows the Media Access Controller (MAC) address of the Ethernet or Wi-Fi port on the Gateway. The MAC address cannot be changed.

Get Address Dynamically Select the Get Address Dynamically check box to configure the Gateway to request an address for use on the network. Most home routers can supply an address automatically to devices on the network. If your router is configured this way, select the Get Address Dynamically check box.

Note that if you wish to use the Widget to access the Gateway from a location outside your local area network, such as your workplace or an Internet cafe, you will find it easier to manage if a static address is set. The easiest way to do this is to first configure the Gateway for a dynamic address so that all the addresses get filled in, then clear the Get Address Dynamically check box and configure only the new static Gateway IP address outside the range of addresses supplied by your router.

Xantrex Gateway Address The Xantrex Gateway Address is the IP address that routers or computers use to connect to the Gateway. If necessary, enter a static IP address that network devices can use to connect to the Gateway.

If your home router does not automatically supply addresses to devices on the network, or if you want the Gateway to have a specific address, clear the Get Address Dynamically check box and enter a static IP address.

Internet Gateway Address This is the IP address of the router, computer, or modem to which the Gateway is connected. Enter an address used by devices on the local network to get out to the Internet.

If your home router cannot supply addresses to devices on the network, or if you want the Gateway to have a specific address, clear the Get Address Dynamically check box and enter a static IP address here.

Name Server Address Enter an address used by devices on the local network which translates names to IP addresses.

If your home router cannot supply addresses to devices on the network, or if you want the Gateway to have a specific address, clear the Get Address Dynamically check box and enter a static IP address here.

Subnet Mask Enter the bits in the IP address which are used to refer to devices on the local network.

If your home router cannot supply addresses to devices on the network, or if you want the Gateway to have a specific address, clear the Get Address Dynamically check box and enter a mask here.

Domain Name Enter a name for the Gateway and the networked power system.

This is the name your power system uses on the network to identify itself to other computers. It is included in all email sent from the Gateway. The default domain name is POWERSYSTEM. This name also appears in the list of auto-detected IP addresses on the Solar Monitor Widget.

After clicking Save and Apply, the Xantrex Gateway reboots with new settings and does not reply for about a minute. This configuration page will attempt to reload with the IP address you set. If the configuration page does not reload, re-enter the IP address of the Gateway in your web browser's address bar.

Configuring Wireless Mode

When configuring wireless network parameters, you must enter as much identical information from your existing network as possible. Before configuring wireless mode, view and record the network wireless settings you are using with your router or computer.

If the Gateway loses connection while configuring wireless mode, the Gateway may have to be reset. Follow the procedure described in “Resetting the Gateway to Factory Defaults” on page 3–21. Before resetting the Gateway, ensure that the Gateway and your computer are connected with an Ethernet cable.

Network Interface. Configures the Gateway to use either a wireless or a hard-wired Ethernet connection for the communications network. Select “Wireless” or “Wired.”

Network Type. Configures the type of wireless connection between the Gateway and your computer. When a wireless router is the connection point between the computer and the Gateway, select “Infrastructure.” Most installations will use “Infrastructure” mode. For a direct connection between the Gateway and a wireless-equipped computer with no connection to the Internet (see Figure 1-8 on page 1–7), select “Ad-Hoc.” “Ad-Hoc” networks also require a radio channel to be set.

Network Name (SSID). Sets the name of the wireless network, or Service Set Identifier (SSID). The SSID is case sensitive and is only used in wireless mode. Set this value to be the same as your existing home network SSID.

An SSID is a unique identifier attached to all packets sent over a wireless network in order separate one network from another. All devices connecting to the same wireless network must use exactly the same SSID.

Radio Channel. Sets the radio channel that your wireless network uses to send messages between devices. Select a radio channel when Network Type is set to Ad-Hoc.

If possible, select a channel unused in your neighborhood. You can use the NetStumbler application (www.netstumbler.com) to help find an unused channel. If all channels are already in use, select the channel which has the lowest radio signal power level. NetStumbler displays signal power levels for every channel it detects.

Note that only channels 1, 6, and 11 are clear channels. All other channels overlap with 1, 6, 11, and each other. If you see channels 1, 2, 3, 4, 5, and 6 in use in a neighborhood, then choose channel 11 to get a clear channel because channels 7 through 10 will overlap with channel 6, reducing your data transmission speed.

Important: Do not configure the radio channel if your Network Type is “Infrastructure.” If you change the radio channel on your router while in Infrastructure mode, the Gateway loses connection. To enable the Gateway to find the router again, remove and reconnect Gateway power by unplugging and reconnecting the Xanbus network cable.

Security. Selects the security type in use on your wireless network. Set this value to be the same as your existing home network.

Wired Equivalent Privacy (WEP) is an early scheme to secure wireless networks. It provides a level of security which may prevent casual snooping.

Wi-Fi Protected Access (WPA) is a class of systems to secure wireless networks. It can provide good security as long as a good pass-phrase is chosen for the encryption key.

Authentication. Configures whether the network uses authentication or not. Set this value to be the same as your existing home network.

For WEP security, “Open/None” means that the wireless network does not perform any authentication. “Shared” means that the wireless network uses a key entered on both the Gateway and the router to authenticate each network packet.

For WPA security, only “Pre-Shared Key (PSK)” can be selected, which ensures that each network packet is authenticated.

Encryption Mode. Configures the level of encryption used on the wireless network. Set this value to be the same as your existing home network.

For WEP security, you can select the encryption strength of either “64 bits” or “128 bits,” where “128 bits” provides a stronger encryption.

For WPA security, only “TKIP” can be selected, which ensures that the encryption dynamically changes keys to provide stronger encryption.

Key Type. Configures the type of the key for either a user-readable passphrase or hexadecimal (“Hex”) numbers. Set this value to be the same as your existing home network. The default setting is “Hex,” which may not match the key type required by your router. For example, Linksys routers require a passphrase when WPA/TKIP security is selected.

Encryption Key. Configures the encryption key used in the wireless network. Set this value to be the same as your existing home network.

Enter the key as hexadecimal numbers if the Hex Key Type was selected above. Enter the key as a string of characters if the Passphrase Key Type was selected above. A passphrase of more than 20 characters is recommended. Spaces and punctuation characters are permitted.

Important: Setting an incorrect Network Name (SSID), security mode, or encryption key causes the Gateway to lose its connection with the network. If the Gateway has lost its connection in this manner, it must be reset to factory default settings.

Configuring Network Time

You can configure the Gateway to use a network time protocol (NTP) server on the Internet. Network time read from the Internet is very accurate.

Universal Coordinated Time (UTC, sometimes referred to as Greenwich Mean Time or GMT) is the default time provided by NTP servers. When using an NTP server, you must enter a Time Zone Offset to shift UTC to your local time.

You can also configure the Gateway to read time from a computer on your local network if the computer has been configured as a NTP server. It is best to use a computer on your local network (if available) so that the Gateway and all computers on the network are synchronized.

If you are unable to contact an NTP server, or are not connected to the Internet, you can set the date and time manually using Local Date and Local Time. Local Date and Local Time use the Gateway internal clock as a reference, which is not as accurate as time from an NTP server.

Important: Network time configured on the Gateway overrides time configured on any individual device in the network-enabled power system. However, XW Hybrid Inverter/Chargers (240V/60Hz models manufactured before April 2008) and XW Solar Charge Controllers (firmware versions prior to 1.03) may not be compatible with NTP.

If your device is not compatible with NTP, inverter/charger features such as Peak Load Shaving and Charger Block may not work correctly, and charge controller daily power production values may reset at an unexpected time. If your device is working incorrectly, select **Use Local Settings** and configure the Gateway to use the local time and date.

Time Zone Offset Sets the local time zone offset from UTC/GMT. Enter the number of hours your local time is offset from UTC/GMT. For locations west of Greenwich, England, the offset should be negative. For locations east of Greenwich, the offset should be positive. Adjust for daylight savings time if it applies in your area.

When updating the Time Zone Offset and no other Network Time settings, select **Update Offset Only** before changing the Time Zone Offset.

Use Local Settings When selected, Local Date and Local Time settings become available. See Figure 3-10. When cleared, you can configure the Gateway to use a network time server.

	<input type="checkbox"/> Update Offset Only
Time Zone Offset	-08:00
	<input checked="" type="checkbox"/> Use Local Settings
Local Date	2008 March 14
Local Time	09:48 AM
Update Time	Save and Update

Figure 3-10 Configuring Local Time

Local Date Sets the date when the Gateway is not connected to an NTP server.

Important: The Gateway may send a Daily Harvest email when the Local Date is manually set.

Local Time Sets the time when the Gateway is not connected to an NTP server.

Time Server Sets the name or IP address of a network time server. Set Time Server to any single NTP time source. It can be set to a randomly selected server such as **pool.ntp.org**, to a server provided by your Internet service provider, or to a computer on your local network if it has been configured as an NTP server.

Important: The Gateway recognizes an NTP server only when **Get Address Dynamically** is selected under **Network Configuration**. See “Get Address Dynamically” on page 3–12. If the Gateway is configured to use a static IP address, select **Local Time**.

	<input type="checkbox"/> Update Offset Only
Time Zone Offset	-08:00
	<input type="checkbox"/> Use Local Settings
Time Server	pool.ntp.org
Server Type	Domain
Update Time	Save and Update

Figure 3-11 Configuring an NTP Server

Server Type Selects the type of time server. Select **Domain** if you use the name of the server, such as pool.ntp.org. Select **IP** if you know the numerical IP address of the server.

Update Time Click **Save and Update** to save the Gateway time configuration. If you have entered a server name or IP address, clicking **Save and Update** also causes the Gateway to update the time using the selected NTP server.

Configuring Email

Types of messages

You can configure the Gateway to send Energy Harvest and System Alarm email to several different email addresses.

The Gateway can send four types of messages:

- Alarm
- Daily Harvest
- Weekly Harvest
- Monthly Harvest

Mail Server Sets the name of the network mail server. Enter the server name that was supplied by your Internet service provider. This should be the same mail server used for the email program already on your computer; for example, **smtp.isp.net**.

Server Type Selects the type of email server. Select **Domain** if you use the name of the server, such as **smtp.isp.net**. Select **IP** if you know the numerical IP address of the server.

To configure each type of message:

1. Enable the message type. You can configure the Gateway to send one or more message types.
2. Add an address list. For each enabled message type, enter one or more email addresses (separated by commas) to receive email from the Gateway.
3. Add a custom message for each enabled message type (optional). You can add text (up to 200 characters) to be included in each email from the Gateway. This text might include system information such as inverter model and solar array specifications, or additional contact information.
4. Click **Send Email** to send a test message to each address in the address list. This helps ensure that the address list, message, and mail server configuration are correct.

The Gateway sends test messages even if there are no inverters or other Xanbus-enabled devices connected to the network. However, if there are no other Xanbus-enabled devices on the network, the Gateway does not automatically send Alarm, Daily, Weekly, or Monthly Harvest messages.

5. Click **Save**.

Note: The basic information you entered under “Home” and the inverter serial number are also included in any email messages the Gateway sends. GT Inverter serial numbers in email messages differ from the firmware serial numbers displayed by the Grid Tie Solar Inverter Monitor, if a Grid Tie Solar Inverter Monitor is installed in your system.

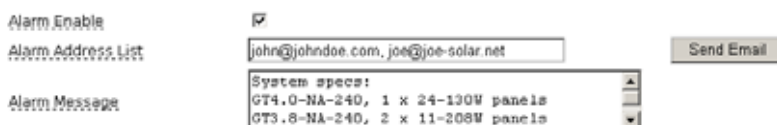

Figure 3-12 Configuring Email

Alarm messages

The Gateway sends an alarm message to alert you whenever a fault occurs in the power system. If a fault occurs while the Gateway is reset or has power removed, the Gateway sends an alarm message when the Gateway is operating again. The Gateway cannot determine if the fault occurred before or while it was powered off, so it will always send an alarm message at startup when there is either an active or logged alarm in the system.

Under some conditions, the Gateway sends a series of alarm messages that may be caused by an intermittent fault, or by the Gateway being repeatedly reset. If the messages become a nuisance and the fault does not clear itself, disable automatic alarm messages and contact your system installer or dealer.

Harvest messages

Energy Harvest email messages contain detailed power production data and can be sent every day, once a week, or once a month.

The Gateway sends harvest email at the same time each day. In a multiple-Gateway system, each unit sends harvest email at a different time. This randomized outgoing email time prevents many Gateways from sending email at the same time. A distributed denial of service (DDOS) could result from every Gateway sending email to the same address at the same time.

Important: The Gateway only makes one attempt to send email. If there is a problem sending the email, the Gateway does not retry at a different time.

Upgrading Device Firmware

To upgrade the firmware for devices in the system, click **Upgrade Device**. You can then select the device you want to upgrade and browse for the latest firmware load. Firmware loads are available from from the Xantrex Web site at www.xantrex.com/gateway or your dealer.

The time it takes to upgrade firmware for a device can vary depending on the device. The Gateway configuration web page displays a progress indicator during the firmware upgrade process. The Modbus/RS485 LED is on steadily during a firmware upgrade.

Important: Close the Solar Monitor Widget before upgrading Gateway firmware or performing any action on the Upgrade Device page. Do not start the Widget until the firmware upgrade is complete.

Important: Do not interrupt network power during the upgrade process. Loss of power or communication during an upgrade may cause an unrecoverable error in the wireless networking module.

The Upgrade Device section of the configuration web page displays the current firmware revision of the:

- Gateway Firmware
- Gateway Bootloader. You cannot upgrade the Gateway bootloader.
- Network Firmware—the internal Lantronix wireless networking module
- Web Page Version—the configuration web page.

Upgrading the Gateway

Two types of upgrade files are available for the Gateway.

1. 150-*<0223,0224,0225>*-xx-xx.wie (150-0223-xx-xx.wie = English, 150-0224-xx-xx.wie = Spanish, 150-0225-xx-xx.wie = German). This file updates the Gateway configuration web page language. Separate files for each language are available on the Gateway Quickstart CD. This file enables you to configure the language on the web page without performing a full Gateway upgrade, which can take

several minutes. For configuration web page upgrades, download the 150-*<0223,0224,0225>-xx-xx.wie* file (or the .zip file that contains this file) from www.xantrex.com/gateway.

2. 150-0221-xx-xx.wie. This file updates the Gateway firmware, the network firmware, and the configuration web page. For firmware upgrades, download the 150-0221-xx-xx.wie file (or the .zip file that contains this file) from www.xantrex.com/gateway.

Upgrading Other Devices

You can use the Gateway to upgrade firmware for any device on the network.

To upgrade firmware for a device on the network:

1. Download and save the latest firmware build for your device from the Xantrex Web site or your dealer.
2. On the Upgrade Device section of the configuration Web page under Select Device, select the device you want to upgrade.

Important: The default device under Select Device is **Gateway**. Ensure you select the correct device before proceeding. The Gateway locks up and needs to be manually reset if the device and the firmware upgrade file are incompatible.

3. Under File Name, click **Browse** and select the firmware upgrade file for the selected device.
4. Click **Upgrade**.

Resetting the Gateway to Factory Defaults

Resetting the Gateway to factory defaults resets all configuration settings and the password. For example, if the Gateway was configured for wireless operation, the reset procedure will return it to wired operation.

After a reset, the Gateway does not clear any of its power harvest history.

The Gateway may have to be reset when configured improperly. If the Gateway has spontaneously lost its network connection without any configuration changes taking place, the connection can usually be re-established by removing and reconnecting Gateway power (unplugging and reconnecting the Xanbus network cable). If removing and reconnecting Gateway power doesn't work, then reset the Gateway to its factory defaults as described below.

To return the Gateway to its factory default settings:

1. Close the configuration web page if it is open.
2. Remove power from the Gateway by unplugging the Xanbus network cable from the Gateway Inverter port.
3. If the Gateway was previously configured for wireless operation, connect an Ethernet cable between the Gateway Ethernet port and your router or computer.
4. Use a pen or small screwdriver to press and hold the Reset button.
5. While holding the Reset button, reconnect the Xanbus network cable to the Gateway Inverter port.
6. Hold the Reset button for an additional ten seconds.
7. Release the Reset button.
8. View the Gateway configuration web page and reconfigure the Gateway.

Power System Monitoring on the Internet

In order to view power system performance data from any location via the Internet, you must change your router firewall settings to allow “port forwarding.” The PORT Forward web site (www.portforward.com) has collected information on how to configure port forwarding for most popular routers.

If you want to monitor your power system on your home network only, you do not need to change your firewall settings.



CAUTION: Network security risk

Changing your firewall settings to allow port forwarding can potentially leave your home network open to attacks from external computers. Do not change your firewall settings unless you are absolutely sure of how to do it correctly. The PORT Forward web site (www.portforward.com) has collected information on how to configure most popular routers.

Xantrex does not guarantee the security of your network if you follow the advice provided at the PORT Forward web site. Use at your own risk.

To configure the Gateway, router and Widget for power system monitoring on the Internet:

1. View the Gateway configuration web page.
2. On the Gateway configuration web page, click **Network Configuration**.
3. Clear the **Get Address Dynamically** check box.
4. Change the last field in the IP address to a number that is outside the DHCP server IP Address Range. You can find this address range on your router's configuration page. Do not use 0, 255, or the same number your router uses (usually 1).

MAC Address	00:20:4A:89:E1:B4	
Get Address Dynamically	<input type="checkbox"/>	
IP Address	192 . 168 . 7 . <input type="text"/>	Change number in this field ↓
Gateway Address	192 . 168 . 7 . 1	
Name Server Address	216 . 21 . 129 . 22	
Subnet Mask	255 . 255 . 255 . 0	
Domain Name	GT-TEST	

5. On the Gateway configuration web page, click **Save and Apply**.

Note: After restarting the Widget on your local network, you may need to manually set the Device IP Address in Widget Preferences to match the chosen address if the Widget cannot automatically detect the new address.

6. In the address bar of the web browser displaying the configuration web page, overwrite the last part of the IP address with the number you entered in step 4.

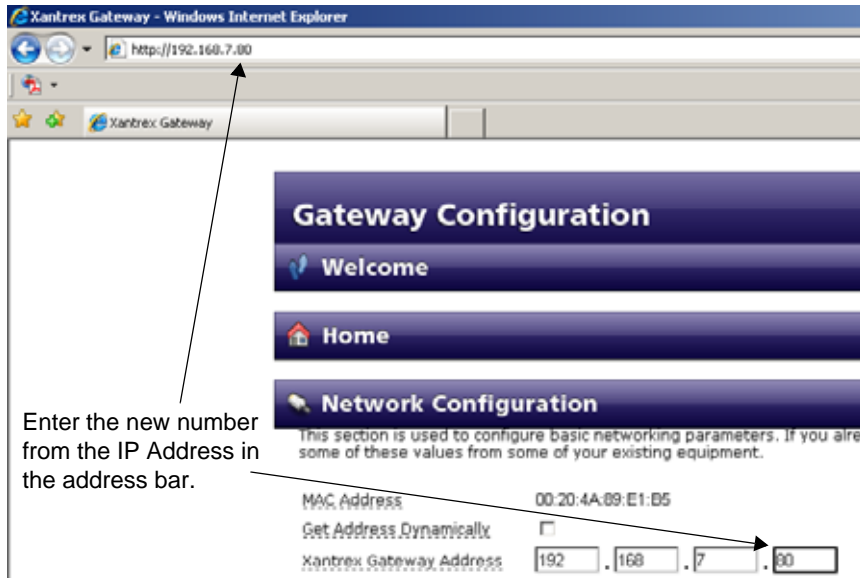

7. Press Enter.
8. Log in to the Gateway configuration web page again to verify the new settings.
9. Find your network's IP address (external IP address).
You can usually find your external IP address on your router's configuration page. If you cannot find your external IP address, the PORT Forward web site automatically detects and displays it.
10. Visit the PORT Forward web site (www.portforward.com) and configure your router to forward to the Gateway IP address.
 - a) Select your router.
 - b) From the list of programs, select **Apache**.
 - c) Follow the instructions to configure Single Port Forwarding for the router. You only need to configure forwarding for Port 80.

Note: If you are familiar with this procedure and are already running an Internet-accessible web server on your home network, you may want to choose a port other than 80 in order to not conflict with the existing service.

11. **From a remote computer outside of your Local Area Network,** start the Solar Monitor Widget. Ensure you are connected to the Internet.

- a) Right-click the Widget and select **Widget Preferences**.
- b) In Widget Preferences, select **Comm**.
- c) Clear the **Auto-detect Device** check box.
- d) In Device IP address, fill in the external IP address of your home network.
- e) Ensure Device Port is set to the same port number you selected in step 10 c).
- f) Click **Save**.

IP Address
Issues

The external IP address that your Internet service provider (ISP) assigns your home router may change from time to time. This change in external IP address prevents the Widget from locating your home network from a remote location.

If your ISP assigns a temporary IP address for your router, you could try a dynamic domain name system (DDNS) service to assign a domain name to your router. This service can automatically handle the changes to your ISP-supplied address. Many routers support DDNS through services like **www.dyndns.com**. You can configure these routers to automatically update the service when your ISP changes your address.

4

Troubleshooting

Chapter 4, “Troubleshooting” contains reference information you can consult if you have problems using the Communications Gateway. This chapter also lists routers that have been tested with the Gateway.

Device Discovery

Consult this table if the Solar Monitor Widget is unable to contact the Gateway at startup.

Problem	Symptom	Cause	Solution
Widget cannot find the Gateway on the network.	Neither LED is on.	Gateway is not powered.	Verify that the Xanbus ports are connected to at least one XW or two GT Inverters. Powering the Gateway from only one GT Inverter requires a separate power supply. Contact Xantrex for more information.
Widget does not discover the Gateway after startup.	Widget shows “Discovering Device – attempt x of 5.”	Improper connection or Gateway is not powered.	Wait at least a minute after the Gateway is powered on. Check connections. When the Gateway is powered, the Gateway Inverter light should blink.
		Solar Monitor Widget configuration or installation incompatibility.	Search your Widget program folder for the xantrex_gateway_discovery_PC or _MAC file. The Gateway CD also has these files. If this discovery program finds the Widget then completely uninstall and reinstall Yahoo! Widgets.
		The Gateway acquired a Link Local address before the router responded with a DHCP address.	Remove and replace Gateway power or wait five minutes after powering the Gateway for the Gateway to respond to the DHCP address from the router.
Widget discovered the Gateway but has no communication.	Modbus/RS485 LED is on steadily.	The Gateway is in bootloader mode.	Upgrade the Gateway software. See “Upgrading Device Firmware” on page 3–20.

Loss of Communication

Consult this table if the Gateway consistently loses contact with your computer or computer network.

Problem	Symptom	Cause	Solution
Gateway is not responding or behaving unexpectedly after startup or configuration change.	Widget shows “Lost Communication.”	Gateway did not finish internal initialization.	Wait for the Gateway to fully initialize. This may take several minutes if there are many devices on the Xanbus network and/or if there is a long history log.
		On the configuration web page you have entered an IP address already used by another computer on the LAN.	Reset the Gateway and reconfigure.
Running Gateway configured for wireless connection loses communication with Widget every night.	Widget shows “Lost Communication,” and resetting the Gateway fixes the problem.	Gateway has a static IP address in the router’s DHCP range.	When using static IP addresses, specify an address that will not conflict with the DHCP range. Otherwise the router may try to reassign the address and knock the Gateway off the network. See “Power System Monitoring on the Internet” on page 3–22.
Wireless communication is lost after setting wireless configuration parameters.	The browser or Widget cannot communicate with the Gateway.	Configuration conflict between the Gateway and your network.	Reset the Gateway and reconfigure. Ensure the following settings are identical to those set in your router: <ul style="list-style-type: none"> • Security • SSID • Authentication • Encryption mode • Key type • Encryption key
		The router’s wireless operation is not compatible with the Gateway.	See “Router Compatibility” on page 4–6 for a list of routers that are known to be incompatible with the Gateway. Try a different router.

Email Messages

Consult this section if you have problems receiving email from the Gateway.

Problem	Cause	Solution
None or only some of the expected email is received from the Gateway.	<p>Email is not configured correctly.</p> <p>The Gateway is not connected to an inverter or other devices on the Xanbus network.</p>	<p>View the configuration web page and ensure that you have enabled the desired message types and entered the correct email server. Your internet service provider can supply your email server details, or you may find your server information in your email program’s account settings.</p> <p>Connect the Gateway to the Xanbus network.</p>
Gateway email arrives from “Unknown sender.”	You have not entered your basic information on the configuration web page.	On the configuration web page, click Home and enter your name and email address.
Different Logged Fault times are displayed in the Solar Monitor Widget and in Alarm email messages.	The Widget’s local computer time is different than the time configured for the Gateway.	Normal operation. The Fault or Alarm times are different when your computer is set to a different time zone than the Gateway. If you are viewing the Widget on a remote computer, the Fault or Alarm times in email and displayed on the Widget may differ.

Miscellaneous Issues

Problem	Symptom	Cause	Solution
After configuring Local Time, the time resets itself to GMT/UTC.	Gateway clock changes unexpectedly.	The Gateway has been configured to read time from an NTP server. The NTP server is overriding the Local Time setting.	Normal operation. If the Gateway has been configured to read time from an NTP server, do not change the Local Date and Local Time settings. To see correct local time on the Gateway when configured to an NTP server, ensure the Time Zone Offset is set correctly.
Unexpected firmware revision displayed after an upgrade.	After a successful upgrade, the revision is still the same as before.	Web browser has cached previous information.	<ul style="list-style-type: none"> • Clear the browser's cache. • Shut down and restart the browser.
Graphs in Widget are not displayed.	Widget shows "No data available to graph."	The Gateway and inverter have not been operating long enough.	Wait for a period boundary crossing before a graph can be displayed. For example, wait until at least a full hour has elapsed before the hourly graph displays any data; until midnight for daily graph, and the first of the month for the monthly graph.
Your changed settings do not appear on the web page.	The Upgrade Device section of the web page shows: Gateway Firmware: Loading... Gateway Bootload: Loading... Network Firmware: Loading... Web Page Version: Loading...	Corrupted Gateway configuration parameters.	Reset the Gateway to factory defaults. See "Resetting the Gateway to Factory Defaults" on page 3–21.
		Internet Explorer 6 is not updating page correctly.	Use another browser, such as Firefox, or quit and restart Internet Explorer 6.
Lifetime Energy Produced displayed on Widget differs from data displayed on the inverter's local display.	n/a	Normal operation.	The Gateway has been connected to an existing power system. The Gateway cannot be calibrated to match power production totals for an existing power system.

Router Compatibility

Xantrex has tested the following routers and found them fully compatible with the Gateway:

- D-Link Wireless N, model DIR655, H/W 02, firmware version 1.02.
- Linksys WRT300N v0.93.9
- Linksys WRT54G v 1.00.9
- Linksys WRT54GL, hardware version 1.1, firmware versions Linksys 4.30.9, Linksys 4.30.11, Tomato version 1.09
- D-Link WBR-1310, hardware version D1, firmware version: 4.00

Xantrex encountered some problems when testing the Gateway with the following routers:

- GigaFast WLAN 11g Router, model WF719-CAPR firmware v1.2.5 (also sold under other generic names). This router works in wired mode only.
- Linksys BEFW11S4 Wireless-B, hardware version 4, firmware version 1.52.02. This router no longer has active support from Linksys. The most recent version of firmware (1.52.02 4/07/2005) does not work with the Gateway in wireless mode.
- Netgear WGR614 v6, firmware versions V1.0.6_1.0.5, V2.0.19_1.0.19NA. This router performs inconsistently in wireless mode.

A

Specifications

Appendix A, “Specifications” contains electrical, mechanical and regulatory specifications for the Communications Gateway.

Electrical Specifications

Nominal input network voltage	15 Vdc, from Xanbus network
Minimum operating network voltage	9 Vdc
Maximum operating network voltage	16 Vdc
Maximum operating current	300 mA @ nominal input network voltage
Communication physical layer	2, CAN
Communication protocol	Xanbus
Maximum Xanbus cable length	130 ft (40 m)
Maximum Ethernet cable length	195 ft (60 m)
Connectors	3 RJ-45—8 pins (2 Xanbus, 1 Ethernet)

Communication Specifications

Ethernet and wireless communications on the Gateway cannot operate simultaneously.

Ethernet	IEEE Std 802.3™-2005
Wireless	802.11.4b and 802.11.4g Channels 1–11 (US/Canada), 1–9 (Europe)
Radiated power	100 mW e.i.r.p. max

History Data Storage

The Gateway stores four types of history in 12 MB of non-volatile internal Flash memory. Data blocks referred to elsewhere (such as “Month” or “Hour” on the Solar Monitor Widget) that are not described below are derived from these data blocks. Each block contains both the energy and the peak power for the period.

1. 48 hours worth of 5 minute blocks for each power port of each device in the network, plus the system total.
2. 2 years worth of 1 day blocks for each power port of each device in the network, plus the system total.
3. 5 years worth of 15 minute blocks for the system total.
4. 1 block for the system total over the lifetime of the Gateway.

Mechanical Specifications

Dimensions (W × H × D)	$6 \frac{11}{16} \times 4 \frac{3}{8} \times 1 \frac{3}{4}$ " (190 × 112 × 45 mm) Height including antenna: $9 \frac{3}{4}$ " (249 mm)
Weight	0.46 lb (207 g)

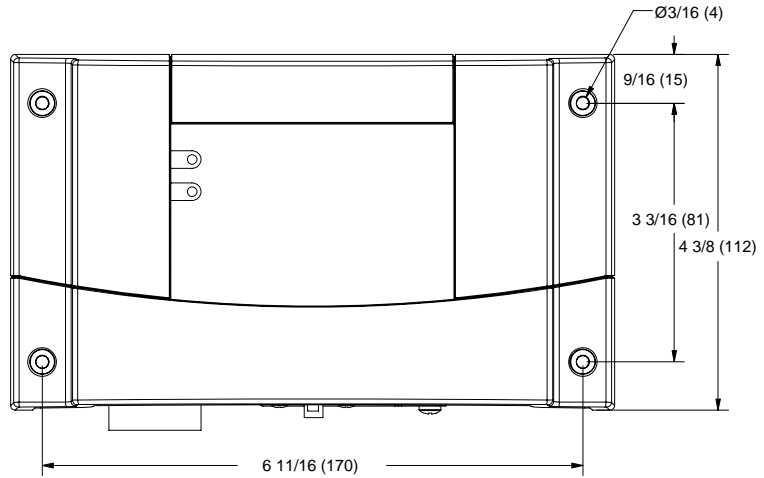

Dimensions in inches (millimeters)

Figure A-1 Gateway Dimensions

Environmental Specifications

Operating temperature	-4 to 122 °F (-20 to 50 °C)
Storage temperature	-40 to 185 °F (-40 to 85 °C)
Operating humidity	5% to 95%, non-condensing
Storage humidity	5% to 95%

Regulatory Compliance

North America

EMC	FCC part 15B class B Industry Canada ICES-003 class B
-----	--

Europe

Safety	Low Voltage Directive 2006/95/EC EN60950-1:2001, protective class III
EMC	EMC Directive 2004/108/EC EN55022 A2:2003 EN55024 A2:2003
Telecom	R&TTE Directive 1999/5/EC ETSI EN 301 489-1 ver. 1.6.1 ETSI EN 301 489-17 ver. 1.2.1

Warranty and Return Information

Warranty

What does this warranty cover and how long does it last? This Limited Warranty is provided by Xantrex Technology Inc. (“Xantrex”) and covers defects in workmanship and materials in your Communications Gateway. This warranty period lasts for 5 years from the date of purchase at the point of sale to you, the original end user customer, unless otherwise agreed in writing (the “Warranty Period”). You will be required to demonstrate proof of purchase to make warranty claims.

This Limited Warranty is transferable to subsequent owners but only for the unexpired portion of the Warranty Period. Subsequent owners also require original proof of purchase as described in "What proof of purchase is required?"

What will Xantrex do? During the Warranty Period Xantrex will, at its option, repair the product (if economically feasible) or replace the defective product free of charge, provided that you notify Xantrex of the product defect within the Warranty Period, and provided that Xantrex through inspection establishes the existence of such a defect and that it is covered by this Limited Warranty.

Xantrex will, at its option, use new and/or reconditioned parts in performing warranty repair and building replacement products. Xantrex reserves the right to use parts or products of original or improved design in the repair or replacement. If Xantrex repairs or replaces a product, its warranty continues for the remaining portion of the original Warranty Period or 90 days from the date of the return shipment to the customer, whichever is greater. All replaced products and all parts removed from repaired products become the property of Xantrex.

Xantrex covers both parts and labor necessary to repair the product, and return shipment to the customer via a Xantrex-selected non-expedited surface freight within the contiguous United States and Canada. Alaska, Hawaii and outside of the United States and Canada are excluded. Contact Xantrex Customer Service for details on freight policy for return shipments from excluded areas.

How do you get service? If your product requires troubleshooting or warranty service, contact your merchant. If you are unable to contact your merchant, or the merchant is unable to provide service, contact Xantrex directly at:

Telephone: 1 866 519 1470 (toll free North America)
1 650 351 8237 (direct)
+49 0180 2240400 (Germany)
+34 902 10 18 13 (Spain)

Fax: 1 604 422 2756 (direct)
+49 (0) 7531 8199868 (Germany)
+34 93 305 50 26 (Spain)

Email: customerservice@xantrex.com

Website: www.xantrex.com

Direct returns may be performed according to the Xantrex Return Material Authorization Policy described in your product manual. For some products, Xantrex maintains a network of regional Authorized Service Centers. Call Xantrex or check our website to see if your product can be repaired at one of these facilities.

What proof of purchase is required? In any warranty claim, dated proof of purchase must accompany the product and the product must not have been disassembled or modified without prior written authorization by Xantrex.

Proof of purchase may be in any one of the following forms:

- The dated purchase receipt from the original purchase of the product at point of sale to the end user; or
- The dated dealer invoice or purchase receipt showing original equipment manufacturer (OEM) status; or
- The dated invoice or purchase receipt showing the product exchanged under warranty.

What does this warranty not cover? Claims are limited to repair and replacement, or if in Xantrex's discretion that is not possible, reimbursement up to the purchase price paid for the product. Xantrex will be liable to you only for direct damages suffered by you and only up to a maximum amount equal to the purchase price of the product.

This Limited Warranty does not warrant uninterrupted or error-free operation of the product or cover normal wear and tear of the product or costs related to the removal, installation, or troubleshooting of the customer's electrical systems. This warranty does not apply to and Xantrex will not be responsible for any defect in or damage to:

- a) the product if it has been misused, neglected, improperly installed, physically damaged or altered, either internally or externally, or damaged from improper use or use in an unsuitable environment;
- b) the product if it has been subjected to fire, water, generalized corrosion, biological infestations, or input voltage that creates operating conditions beyond the maximum or minimum limits listed in the Xantrex product specifications including, but not limited to, high input voltage from generators and lightning strikes;
- c) the product if repairs have been done to it other than by Xantrex or its authorized service centers (hereafter "ASCs");
- d) the product if it is used as a component part of a product expressly warranted by another manufacturer;
- e) component parts or monitoring systems supplied by you or purchased by Xantrex at your direction for incorporation into the product;
- f) the product if its original identification (trade-mark, serial number) markings have been defaced, altered, or removed;
- g) the product if it is located outside of the country where it was purchased; and
- h) any consequential losses that are attributable to the product losing power whether by product malfunction, installation error or misuse.

Disclaimer

Product

THIS LIMITED WARRANTY IS THE SOLE AND EXCLUSIVE WARRANTY PROVIDED BY XANTREX IN CONNECTION WITH YOUR XANTREX PRODUCT AND IS, WHERE PERMITTED BY LAW, IN LIEU OF ALL OTHER WARRANTIES, CONDITIONS, GUARANTEES, REPRESENTATIONS, OBLIGATIONS AND LIABILITIES, EXPRESS OR IMPLIED, STATUTORY OR OTHERWISE IN CONNECTION WITH THE PRODUCT, HOWEVER ARISING (WHETHER BY CONTRACT, TORT, NEGLIGENCE, PRINCIPLES OF MANUFACTURER'S LIABILITY, OPERATION OF LAW, CONDUCT, STATEMENT OR OTHERWISE), INCLUDING WITHOUT RESTRICTION ANY IMPLIED WARRANTY OR CONDITION OF QUALITY, MERCHANTABILITY OR FITNESS FOR A PARTICULAR PURPOSE. ANY IMPLIED WARRANTY OF MERCHANTABILITY OR FITNESS FOR A PARTICULAR PURPOSE TO THE EXTENT REQUIRED UNDER APPLICABLE LAW TO APPLY TO THE PRODUCT SHALL BE LIMITED IN DURATION TO THE PERIOD STIPULATED UNDER THIS LIMITED WARRANTY.

IN NO EVENT WILL XANTREX BE LIABLE FOR: (A) ANY SPECIAL, INDIRECT, INCIDENTAL OR CONSEQUENTIAL DAMAGES, INCLUDING LOST PROFITS, LOST REVENUES, FAILURE TO REALIZE EXPECTED SAVINGS, OR OTHER COMMERCIAL OR ECONOMIC LOSSES OF ANY KIND, EVEN IF XANTREX HAS BEEN ADVISED, OR HAD REASON TO KNOW, OF THE POSSIBILITY OF SUCH DAMAGE; (B) ANY LIABILITY ARISING IN TORT, WHETHER OR NOT ARISING OUT OF XANTREX'S NEGLIGENCE, AND ALL LOSSES OR DAMAGES TO ANY PROPERTY OR FOR ANY PERSONAL INJURY OR ECONOMIC LOSS OR DAMAGE CAUSED BY THE CONNECTION OF A PRODUCT TO ANY OTHER DEVICE OR SYSTEM; AND (C) ANY DAMAGE OR INJURY ARISING FROM OR AS A RESULT OF MISUSE OR ABUSE, OR THE INCORRECT INSTALLATION, INTEGRATION OR OPERATION OF THE PRODUCT BY PERSONS NOT AUTHORIZED BY XANTREX.

IF YOU ARE A CONSUMER (RATHER THAN A PURCHASER OF THE PRODUCT IN THE COURSE OF A BUSINESS) AND PURCHASED THE PRODUCT IN A MEMBER STATE OF THE EUROPEAN UNION, THIS LIMITED WARRANTY SHALL BE SUBJECT TO YOUR STATUTORY RIGHTS AS A CONSUMER UNDER THE EUROPEAN UNION PRODUCT WARRANTY DIRECTIVE 1999/44/EC AND AS SUCH DIRECTIVE HAS BEEN IMPLEMENTED IN THE EUROPEAN UNION MEMBER STATE WHERE YOU PURCHASED THE PRODUCT. FURTHER, WHILE THIS LIMITED WARRANTY GIVES YOU SPECIFIC LEGAL RIGHTS, YOU MAY HAVE OTHER RIGHTS WHICH MAY VARY FROM EU MEMBER STATE TO EU MEMBER STATE OR, IF YOU DID NOT PURCHASE THE PRODUCT IN AN EU MEMBER STATE, IN THE COUNTRY YOU PURCHASED THE PRODUCT WHICH MAY VARY FROM COUNTRY TO COUNTRY AND JURISDICTION TO JURISDICTION.

Return Material Authorization Policy

For those products that are not being repaired in the field and are being returned to Xantrex, before returning a product directly to Xantrex you must obtain a Return Material Authorization (RMA) number and the correct factory "Ship To" address. Products must also be shipped prepaid. Product shipments will be refused and returned at your expense if they are unauthorized, returned without an RMA number clearly marked on the outside of the shipping box, if they are shipped collect, or if they are shipped to the wrong location.

When you contact Xantrex to obtain service, please have your instruction manual ready for reference and be prepared to supply:

- The serial number of your product
- Information about the installation and use of the unit
- Information about the failure and/or reason for the return
- A copy of your dated proof of purchase

Record these details on page WA-5.

Return Procedure

Package the unit safely, preferably using the original box and packing materials. Please ensure that your product is shipped fully insured in the original packaging or equivalent. This warranty will not apply where the product is damaged due to improper packaging.

Include the following:

- The RMA number supplied by Xantrex Technology Inc. clearly marked on the outside of the box.
- A return address where the unit can be shipped. Post office boxes are not acceptable.
- A contact telephone number where you can be reached during work hours.
- A brief description of the problem.

Ship the unit prepaid to the address provided by your Xantrex customer service representative.

If you are returning a product from outside of the USA or Canada In addition to the above, you **MUST** include return freight funds and are fully responsible for all documents, duties, tariffs, and deposits.

If you are returning a product to a Xantrex Authorized Service Center (ASC) A Xantrex return material authorization (RMA) number is not required. However, you must contact the ASC prior to returning the product or presenting the unit to verify any return procedures that may apply to that particular facility and that the ASC repairs this particular Xantrex product.

Out of Warranty Service

If the warranty period for your product has expired, if the unit was damaged by misuse or incorrect installation, if other conditions of the warranty have not been met, or if no dated proof of purchase is available, your unit may be serviced or replaced for a flat fee.

To return your product for out of warranty service, contact Xantrex Customer Service for a Return Material Authorization (RMA) number and follow the other steps outlined in "Return Procedure" on page WA-3.

Payment options such as credit card or money order will be explained by the Customer Service Representative. In cases where the minimum flat fee does not apply, as with incomplete units or units with excessive damage, an additional fee will be charged. If applicable, you will be contacted by Customer Service once your unit has been received.

Information About Your System

As soon as you open your Communications Gateway package, record the following information and be sure to keep your proof of purchase.

- Serial Number _____
- Product Number 865-1055 (North America), 865-1056 (Europe)
- Purchased From _____
- Purchase Date _____

If you need to contact Customer Service, please record the following details before calling. This information will help our representatives give you better service.

- Type of installation (e.g. RV, truck) _____
- Length of time inverter has been installed _____
- Battery/battery bank size _____
- Battery type (e.g. flooded, sealed gel cell, AGM) _____
- DC wiring size and length _____
- Alarm sounding? _____
- Description of indicators on front panel _____
- Appliances operating when problem occurred _____
- Description of problem _____

Index

C

- communication loss 4–3
- configuration
 - baud rate 3–11
 - email 3–18
 - monitoring on the Internet 3–22
 - network time 3–15, 4–5
 - wireless mode 3–13
- Customer Service
 - preparing to call WA–5

D

- device discovery 3–2, 4–2

E

- email
 - configuring 3–18
 - troubleshooting 4–4
- environmental specifications A–4
- external features 1–3, 1–4

G

- Gateway
 - firmware revision 3–20
 - IP address 3–2, 3–5, 3–8
- GT Inverter network ports 2–9

I

- Information about Your System form WA–5
- installation
 - distance between devices 2–3
 - location 2–3
 - materials and tools 2–4
 - mounting 2–5
 - routing cables 2–8

inverter

- purchase date WA–5
- serial number WA–5

K

- Konfabulator 2–12

M

- mechanical specifications A–3
- mounting the Gateway 2–5

N

- network components 2–6
- network layout 1–5, 2–8
- network time 3–15, 4–5
- network verification 2–11

P

- password, changing 3–10
- port forwarding 1–7, 3–22
- powering the Gateway 2–11
- proof of purchase WA–5
- purchase date WA–5

R

- remote monitoring 3–22
- reset button 1–4
- resetting the Gateway 3–21
- routers 4–6

S

- serial number WA–5
- Solar Monitor Widget 2–12, 3–6, 4–5

T

- time, configuring 3–15, 4–5

Index

troubleshooting
 device discovery 4–2
 email 4–4
 lost communication 4–3
 network time 4–5

U

upgrading devices 3–20

W

warranty
 terms and conditions WA–1
Widget
 graphs 4–5
 preferences 3–6
 system requirements 2–12
wireless mode, configuring 3–13

X

Xantrex
 web site vi
XW Hybrid Inverter/Charger network ports 2–10

Y

Yahoo! Widgets 2–12

Xantrex Technology Inc.

1 866 519 1470 Tel toll free NA

1 650 351 8237 Tel direct

+34 902 10 18 13 (Europe)

1 604 422 2756 Fax direct

+34 93 305 50 26 (Europe)

customerservice@xantrex.com

www.xantrex.com

support.europe@xantrex.com