

# POLESIDES™

## Series 4012 Fixed Tilt Side-of-Pole Rack for a Single PV Module on 2-Inch Pole

(Formerly U-PS Series F)

### Installation Sheet 404.1

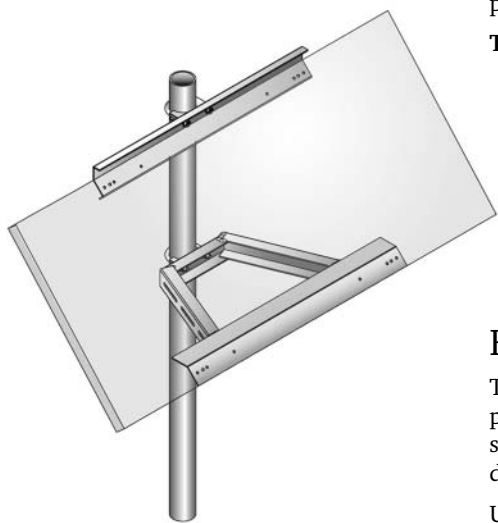

Thank you for purchasing a UniRac. Please read these guidelines completely before proceeding.

The installer is solely responsible for:

- Complying with all applicable local or national building codes, including any that may supercede this manual;
- Ensuring that UniRac and other products are appropriate for the particular installations and are designed for the installation environment;
- Using only UniRac parts and installer-supplied parts as specified by UniRac (substitution of parts will void the warranty);
- Ensuring safe installation of all electrical aspects of the PV array.

#### Before assembly

This rack is intended for mounting on a 2-inch Schedule 40 or Schedule 80 steel pole (O.D. 2.375), which is not included with the rack. To the greatest extent possible, the installation site should allow unshaded exposure to the sun throughout daylight hours.

Use the Parts List to verify that all parts are present.

#### Parts List

Part	Qty	Wrench size	Recommended torque (ft-lbs)
Upper bracket	1		
Welded lower bracket	1		
Saddle clamp w/ 5/16" hardware	2	1/2"	15
Hexhead bolt, 1/4"	4	7/16"	15
Flange nut, 1/4"	4	7/16"	15

#### Caution

Stainless steel hardware can seize up, a process called galling. To significantly reduce the likelihood of galling, apply a small drop of anti-seize lubricant to the threads of all bolts before installation. Anti-seize lubricants are readily available in auto parts and hardware stores. In their absence, any lubricant will reduce chances of galling.

#### Mounting pole guidelines

The installer is solely responsible for use of the information below. These are general guidelines for normal installations. The following variances can affect your installation:

- The required diameter and depth of the hole are dependent on soil type, which varies by locale. An installation in loose, sandy soil will require larger, deeper holes and, therefore, more concrete than an installation in soil of average density.
- The depth and width of the hole should also be increased in areas subject to winds in excess of 90 mph, particularly if the location of the mounting pole is open and unprotected.

- Poles taller than 6 feet above ground require that the depth of the hole be increased.

If in doubt, consult a professional civil engineer who is familiar with local soil conditions and wind load requirements.

1. Dig a hole 8 to 12 inches in diameter and 36 to 40 inches deep. Fill the bottom with 4 inches of gravel.
2. Stand the pipe in the hole. Brace the pole so that it is plumb. Pour concrete around the pipe, filling the hole to ground level. Add an inch or two of extra concrete above the hole. Use a trowel to slope the concrete around the pole.
3. Allow the concrete to set up for at least 24 hours before installing your UniRac.

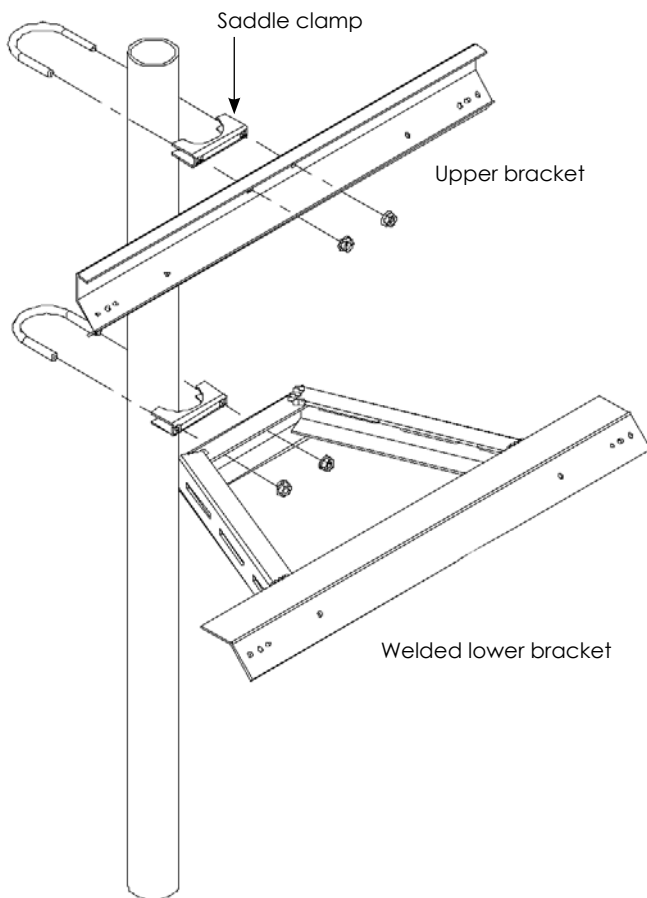

### Assembly

Figure 2 illustrates the relationship of the parts. Lay your PV module face down on its carton or another surface that will not damage the glass.

Using ¼-inch hardware, attach the welded lower bracket and upper bracket to the module. Ensure that the upper and lower brackets are centered along the length of the module. Securely tighten all module bolts.

Mount the module and frame to the pole with the U-bolts, clamps, and 5/16-inch flange nuts (components of the saddle clamps). Ensure that the brackets are centered on the saddle clamps.

Finger tighten the flange nuts.

### Final adjustment

For optimum performance, the solar panel must face true south (for northern hemisphere locations) or north (southern hemisphere). Rotate the assembly on the pole to the correct orientation.

Tighten the saddle clamps securely.

## 10 year limited Product Warranty

UniRac, Inc., warrants to the original purchaser ("Purchaser") of product(s) that it manufactures ("Product") at the original installation site that the Product shall be free from defects in material and workmanship for a period of ten (10) years, from the earlier of 1) the date the installation of the Product is completed, or 2) 30 days after the purchase of the Product by the original Purchaser. This Warranty does not cover damage to the Product that occurs during its shipment, storage, or installation.

This Warranty shall be VOID if installation of the Product is not performed in accordance

with UniRac's written installation instructions, or if the Product has been modified, repaired, or reworked in a manner not previously authorized by UniRac IN WRITING, or if the Product is installed in an environment for which it was not designed. UniRac shall not be liable for consequential, contingent or incidental damages arising out of the use of the Product by the Purchaser under any circumstances.

If within the specified Warranty period the Product shall be reasonably proven to be defective, then UniRac shall repair or replace the defective Product, or any part thereof,

in UniRac's sole discretion. Such repair or replacement shall completely satisfy and discharge all of UniRac's liability with respect to this limited Warranty. Under no circumstances shall UniRac be liable for special, indirect or consequential damages arising out of or related to use by Purchaser of the Product.

Manufacturers of related items, such as PV modules and flashings, may provide written warranties of their own. UniRac's limited Warranty covers only its Product, and not any related items.

